



*A Clean Energy Company*

# TECHNICAL MANUAL

The Solar Eclipse™ Mobile Solar Generator  
DC Solar Distribution



The information described in this manual is distributed under license from DC SOLAR Distribution, Inc.. Your license agreement specifies the permitted and prohibited uses of this manual. Any unauthorized duplication or distribution of *Technical Manual: The Solar Eclipse™ Mobile Solar Generator*, in whole or in part, in print, or in any other format is prohibited.

Every attempt has been made to make this document complete, accurate and up-to-date. Readers are cautioned, however, that DC SOLAR Distribution, Inc. is not responsible for damages caused by reliance upon this manual or any errors therein, including, but not limited to, typographical, arithmetical, or listing errors and omissions. DC SOLAR Distribution, Inc., reserves the right to make changes to this manual without notice and shall not be responsible for updating the user with such changes or additions.

This Technical Manual is provided as a courtesy and “as is” without warranty of any kind, either expressed or implied. While the information in this manual has been carefully checked, DC SOLAR Distribution, Inc. cannot be responsible for errors and reserves the right to change the specifications without notice. The use of any information found in this manual will be entirely at the user’s risk.

This manual is Copyright © 2017, DC SOLAR Distribution, Inc.  
Solar Eclipse is a registered trademark of DC SOLAR SOLUTIONS MFG., Inc.  
Sunny Island 6048-US is a registered trademark of SMA Solar Technology  
AG Midnite Classic 250 is a registered trademark of Midnite Solar, Inc  
Phono Solar is a trademark of Phono Solar Technology Co., Ltd.  
Kubota Lowboy II: GL7000 & GL11000 is a registered trademark of Kubota Corporation  
US Tower: Light Mast is a registered trademark of US Tower Corporation  
ChargePoint: CT4000 series is a registered trademark of ChargePoint, Inc.  
CEP: 6506GU is a registered trademark of Construction Electrical Products, Inc.  
4660-SG Fuel Cell is a registered trademark of ECI Fuel Systems.  
GNB Tubular LMX is a registered trademark of Exide Technologies.

All other trademarks and registered trademarks are property of their respective holders.

Manual version: 3.0  
Corresponds to DC Solar Distribution version  
November 2017



## **SAFETY GUIDELINES & WARNINGS**

**It is important for you to read and understand this Technical Manual. The information it contains relates to protecting YOUR SAFETY and PREVENTING PROBLEMS.**

### SYMBOLS USED IN THIS MANUAL



**WARNING** - failure to heed the instructions may lead to death, serious injury or serious damage to the equipment.



**CAUTION** - negligence of the instructions may lead to damage to this equipment, injury and/or property damage.



**INFORMATION/REFERENCE** - indicates reference functions related to a topic and/or settings related to a certain function.

# Table of Contents

Legal Notices .....	i
Advisements/Warnings .....	ii
Table of Contents .....	iii
Identifying Equipment and Components of The Solar Eclipse .....	v
Portfolio.....	vi
<b>Quick Start Guide</b> .....	<b>1</b>
1.1 Quick Starting The Solar Eclipse .....	2
Deploying Solar Panels (See Section 2 for more detail).....	2
Activation (See Sections 2 and 3 for more detail).....	2
1.2 Deactivation.....	3
Within the Enclosure:.....	3
At the Master Inverter:.....	3
<b>Trailer &amp; PV Arrays</b> .....	<b>5</b>
2.1 Overview .....	6
2.2 Transporting.....	6
2.3 Positioning the Trailer .....	7
2.4 Positioning the PV Arrays.....	7
2.5 Frequently Asked Questions .....	8
<b>Enclosure Cabinet</b> .....	<b>9</b>
3.1 Important Paperwork.....	10
3.2 PV Combiner Box .....	10
3.3 100 Amp Load Center.....	11
3.4 Inverters.....	11
3.5 The Charge Controller .....	12
Commissioning (Quick Set).....	12
Menus and MNGP Features.....	13
Accessing Charge Controller Wiring.....	13
DC GFP (Ground Fault Protection).....	13
Arc Fault Detector (AFD).....	18
3.6 Frequently Asked Questions .....	19
<b>Inverters</b> .....	<b>21</b>
4.1 Overview .....	22
Display.....	22
Keypad .....	22
Menus .....	23
Breaker and SD card.....	23
4.2 Switching ON and OFF.....	23
Starting Inverters.....	23
Stopping Inverters (Standby, Switching Off, and Disconnecting).....	24
Reactivating the Device Following Automatic Shutdown.....	24
4.3 Menus and Parameters.....	24
Menu Structure – See Table 2 (next page) for Menu Map. ....	24
Changing Parameters.....	27
4.4 Display .....	28

LED Indicators.....	30
4.5 Events, Warnings, and Failures.....	30
Display of Events and Errors.....	31
Error and Event Codes.....	31
Failure Confirmation.....	32
Handling Pending Failures during the Booting Procedures.....	32
4.6 Generator Management: See Section 6.1.....	32
4.7 Frequently Asked Questions.....	32
<b>Batteries and Outlets</b>	<b>37</b>
5.1 Battery Charge Stages on the Charge Controller.....	38
5.2 Battery Metering on the Inverter.....	38
5.3 Non-PV Battery Charge.....	39
5.4 Outlets.....	39
SCT20 Models.....	39
Spider Box.....	40
5.5 Frequently Asked Questions.....	40
<b>Enhancements</b>	<b>41</b>
6.1 External Power Generator.....	42
SCT20 Hybrid Series.....	42
Operating Modes.....	43
Autostart.....	43
Run Procedure.....	43
Time Remaining.....	44
Manual Operation.....	44
Faults and Failures.....	45
6.2 Light Tower.....	45
Setting up the Light Tower Masts.....	45
6.3 Electric Vehicle Charger.....	48
Deploying the EV Charger.....	50
Preparing for transit/storage.....	50
6.4 Power Station.....	50
Deploying the Power Station.....	50
Preparing for Transit/Storage.....	51
6.5 Fuel Cell.....	52
<b>Maintenance</b>	<b>53</b>
7.1 Trailer.....	54
7.2 PV Arrays.....	54
7.3 Inverter and Charge Controller.....	54
7.4 Battery.....	54
7.5 Storage.....	54
<b>Appendices</b>	<b>55</b>
8.1 List of Figures.....	56
8.2 List of Tables and Diagrams.....	58
8.3 Additional References.....	58
8.4 Glossary.....	59
8.5 Inverter Events.....	63



# Identifying Equipment and Components of The Solar Eclipse

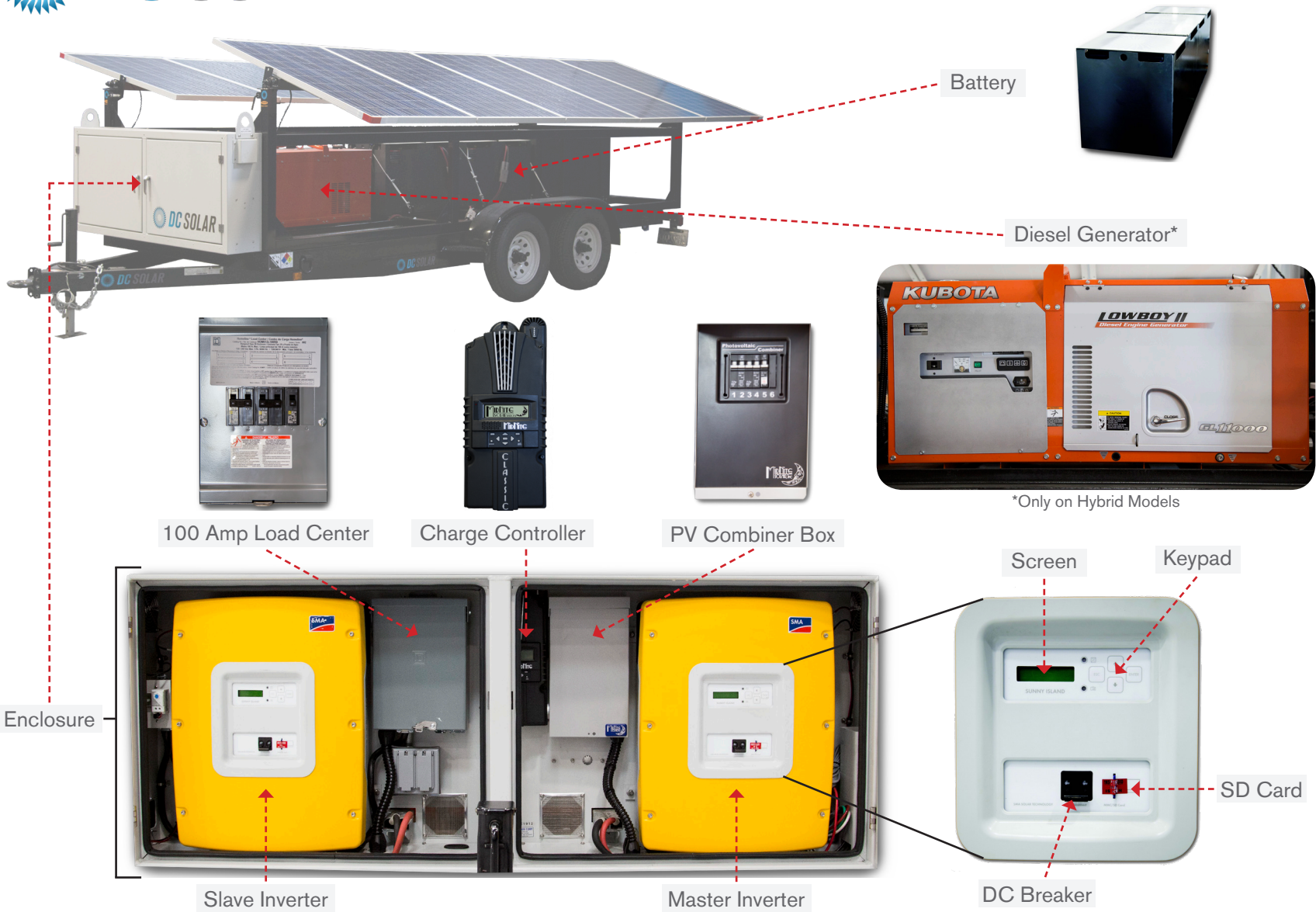

## Portfolio

MODEL:	SCT20	SCT20 Hybrid	SCT20 Hybrid Light Tower	SCT20 Power Station	SCT20 Hybrid EV Charger
<b>Dimensions</b>					
Transport (L x W x H)	21'6" x 8'2" x 8'4"	21'6" x 8'2" x 8'4"	23'7" x 8'2" x 9'4"	21'6" x 8'2" x 8'4"	22'6" x 8'2" x 8'4"
Deployed (W x H)	11'11" x 5'9"-8'4"	11'11" x 5'9"-8'4"	11'11" x 26' 6"	11'11" x 5'9"-8'4"	11'11" x 5'9"-8'4"
GVWR	8,400 lbs.	8,500 lbs.	9,000 lbs.	8,400 lbs.	8,500 lbs.
Hitch	Pintle	Pintle	Pintle	Pintle	Pintle
<b>PV Arrays</b>					
Total Input (Watts)	2,400 W	2,400 W	2,400 W	2,400 W	2,400 W
Movement	Manual	Manual	Manual	Manual	Manual
<b>AC Output</b>					
Nominal AC Voltage	120/240 V	120/240 V	120/240 V	120/240 V	120/240 V
Nominal Frequency	60 Hz	60 Hz	60 Hz	60 Hz	60 Hz
Continuous AC output at 77°F/113°F (25°C/45°C)	5kW / 4kW	5kW / 4kW	5kW / 4kW	5kW / 4kW	5kW / 4kW
AC output power at 77°F (25°C) for 30min/1min/3sec	12kW / 16.8kW / 24kW	12kW / 16.8kW / 24kW	12kW / 16.8kW / 24kW	12kW / 16.8kW / 24kW	12kW / 16.8kW / 24kW
Nominal AC current/ max AC current (peak)	41.7A / 180A for 60ms	41.7A / 180A for 60ms	41.7A / 180A for 60ms	41.7A / 180A for 60ms	41.7A / 180A for 60ms
THD output voltage/ power factor	<3% / -1 to +1	<3% / -1 to +1	<3% / -1 to +1	<3% / -1 to +1	<3% / -1 to +1
<b>AC Input (Kubota GL11000 Generator)</b>					
Input Voltage	n/a	120/240V	120/240V	n/a	120/240V
Input Frequency	n/a	60-64 Hz	60-64 Hz	n/a	60-64 Hz
Max AC Input Current	n/a	83.3/41.7A	83.3/41.7A	n/a	83.3/41.7A
<b>DC Output</b>					
Battery Type	FLA @ 48V DC	FLA @ 48V DC	FLA @ 48V DC	FLA @ 48V DC	FLA @ 48V DC
Battery Capacity	1,020 Ah	1,020 Ah	1,020 Ah	1,020 Ah	1,020 Ah



# Quick Start Guide



## 1.1 Quick Starting The Solar Eclipse

Park the Solar Eclipse in an open area free from shade. The hitch should point east or west for optimum performance.

### Deploying Solar Panels (See Section 2 for more detail)



*DC Solar recommends this be carried out by two adults for your safety.*

1. Pull out on the spring-loaded locking pins at each end of the PV arrays and rotate clockwise to hold springs compressed (§ 2.4).
2. Rotate the PV arrays to desired angle, then turn the pins counterclockwise to lock panels in place.

### **Activation** (See Sections 2 and 3 for more detail)

1. Unlock and open the Enclosure doors.
2. Switch the DC-disconnect for the Slave Inverter to the ON position, and then switch ON the DC-disconnect for the Master Inverter.
3. Wait until the Master display reads “STNDBY: To Start INV press <ENTER>”, then press and hold <ENTER>; the display will show a progress bar (Fig. 1).
4. Identify the three types of components found inside: (§ 3)
  - PV Combiner Box (right-center)
  - Charge Controller (center)
  - 100 Amp Load Center (left-center)

Open PV Combiner Box from the bottom and switch breakers 1-5 to the ON position.

5. Visually verify that the Charge Controller LED display is ON and measuring PV current.
6. Open 100 Amp Load Center from the bottom and switch breakers 1-6 to the ON position.
7. Close Enclosure doors.

You can now plug your equipment into the outlets.



**Figure 1**  
Startup Inverter Display

## 1.2 Deactivation



*Remove any equipment plugged into the outlets before deactivating Inverters.*

### Within the Enclosure:

1. Open PV Combiner Box (right-center) from the bottom.
2. Switch breakers 1-5 to the OFF position.
3. Visually verify that the LED display on the Charge Controller (center) is OFF.

### At the Master Inverter:

4. Press and hold <ESC> until Inverter display reads:  
"STNDBY: To Start  
INV hold <ENTER>"  
(See Fig. 2)
5. Switch the DC-disconnect for the Master Inverter to the OFF position, followed by the DC-disconnect for the Slave Inverter.
6. Close and secure the doors to the Enclosure.

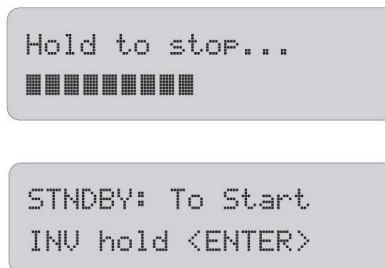

**Figure 2**  
Stopping Inverter Display



# Trailer & PV Arrays



This section will cover:

- ✓ Safety measures for transporting or shipping the Solar Eclipse
- ✓ Optimal positioning of the Solar Eclipse
- ✓ Safe deployment of the PV panels

## 2.1 Overview

There are two rows of PV Arrays on the Solar Eclipse. Each row consists of five panels. (Fig. 3)



**Figure 3**

Arrays in position for transportation.

## 2.2 Transporting

Anytime the Solar Eclipse is towed or shipped, the PV arrays need to be locked in the upright, vertical position for safe transportation.

Before towing the Solar Eclipse:

- Lock the arrays upright.
- Secure the pintle / ball hitch.
- Then, attach the two safety chains, the 7-way connector, and the breakaway cable to the main vehicle. (Fig. 4)

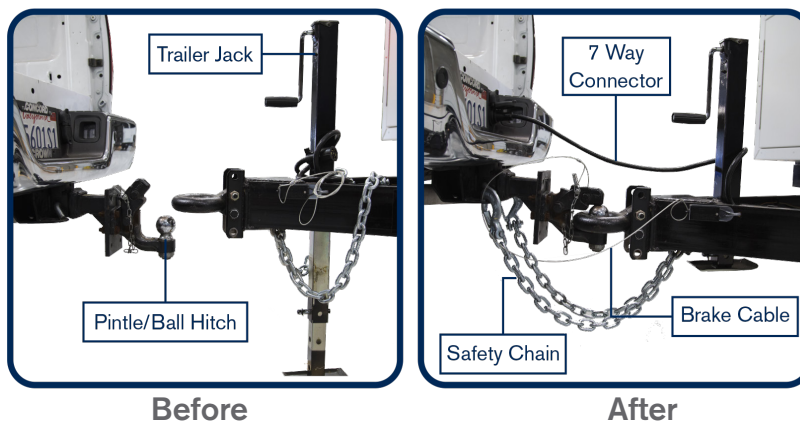

**Figure 4**

Securing the Solar Eclipse For Transport



*Make sure the breakaway cable is free from obstruction, and that the trailer brakelights work properly, before transporting the trailer.*

## 2.3 Positioning the Trailer

The Solar Eclipse trailer should be parked in an open area with adequate clearance to deploy the panels free from shade. For best results, point the Solar Eclipse's hitch east or west, although environmental constraints may require the hitch to be pointed south or north.



Anytime the Solar Eclipse is not in motion, place a block or wedge under the tires to prevent the Solar Eclipse from rolling.



Any shade (or dust—See section 7 for cleaning instructions) will decrease the sunlight absorbed by the panels, thus reducing efficiency and power output.

## 2.4 Positioning the PV Arrays



DC Solar Distribution recommends that two adults work together for safe deployment of the PV arrays, one near the hitch and the other at the rear.



The PV arrays hang low: take care to avoid collisions when deploying or adjusting. The corners on PV arrays are marked with reflective tape for your protection.

There are four spring-loaded locking pins per Solar Eclipse, with two on each PV array at both ends. (Fig. 5)

Pull the pins on each end of the arrays, turning clockwise to hold the springs compressed, then adjust arrays to desired angle; rotate pins counterclockwise and let slide back in to lock arrays in position (Fig. 5); repeat for the second row of PV arrays. Confirm the arrays are free from shading and adjust the angle as necessary.

In general, if the Solar Eclipse is parked with the hitch pointed east or west, the arrays can be deployed flat; if there is no shading, the arrays can remain flat throughout use. However, if the Solar Eclipse's hitch is pointed north or south, adjustment of the PV arrays may be necessary over the course of the day.

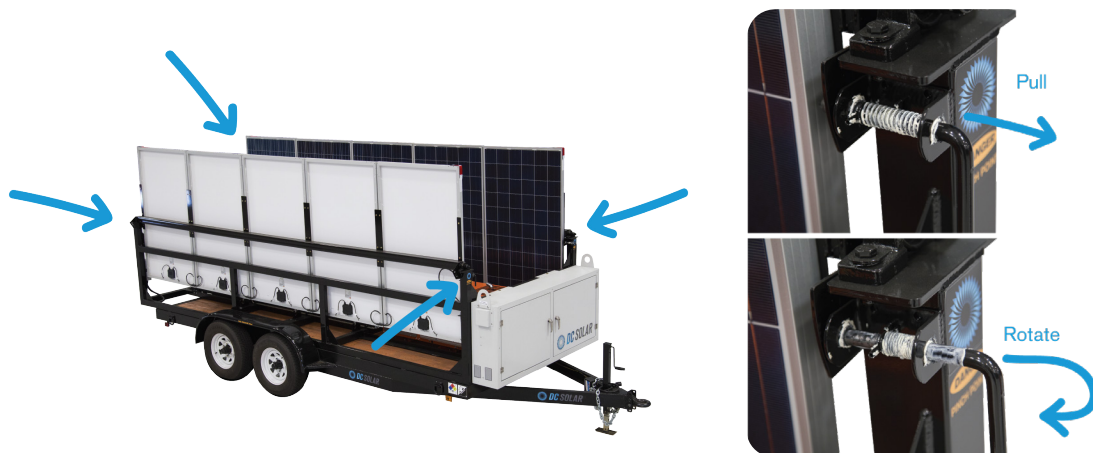

**Figure 5**  
Locating the locking pins

## 2.5 Frequently Asked Questions

### Q: Do I need to change the angle of my PV arrays throughout the day?

As a general rule, be aware of any shading on the PV arrays and make necessary adjustments to maximize the area of the panel exposed to sunlight.

Optimal use of PV arrays occurs when the Solar Eclipse hitch is pointed east or west, with the panels deployed flat and free of shade, in which case adjustment of the PV arrays may not be necessary. If the Solar Eclipse is pointed north or south, however, adjustments may be necessary to maximize efficiency.

### Q: The PV Arrays look dirty—are they still able to charge?

It is recommended that the arrays are kept clean and free from dust or dirt in order to maximize the amount of sunlight absorbed and thus the efficiency. See Section 7 for cleaning instructions.

### Q: Can I tow the Solar Eclipse with PV Arrays deployed?



**No! Never attempt to tow Solar Eclipse with arrays deployed. Jolts and vibrations from transport may cause damage to the panels and connections if they are not secured in the upright position.**

### Q: The PV arrays are deployed, is my battery charging even though I haven't turned on the equipment?



*No! The PV arrays will only charge the battery when ALL breakers (numbered 1-5) on the PV Combiner Box (located in the Enclosure) are switched to the "ON" position. See section 4.*

# Enclosure Cabinet



This section will cover:

- ✓ Where to find important paperwork.
- ✓ Key equipment located inside the unit's Enclosure.
- ✓ How to operate the Charge Controller.

## 3.1 Important Paperwork

Quick Start instructions for the Solar Eclipse are on a sticker on the inside of the right Enclosure door.

The Enclosure key, the Fuel Cell key, the Generator key (if applicable), and a laminated copy of the registration can be found inside the Enclosure on a caribiner hanging from the 100 Amp Load Center. The registration identifies the vehicle identification number (VIN) and the license plate number.



*The Department of Motor Vehicles (DMV) requires that all vehicles carry registration on board.*

## 3.2 PV Combiner Box

The PV Combiner Box (Fig. 6) sits right-center inside the Enclosure (See “Identifying Equipment and Components of The Solar Eclipse”).

To expose the breakers, lift up the cover from the bottom.

- 2-pole breaker 1-2 manages the left array of PV panels.
- 2-pole breaker 3-4 manages the right array of PV panels.
- 1-pole breaker 5 manages the Charge Controller.
- 1-pole breaker 6 manages the lights (if applicable).



**Figure 6**  
PV Combiner Box

### 3.3 100 Amp Load Center

The 100 Amp Load Center (Fig. 7) sits left-center in the Enclosure. Expose the breakers by lifting the locking hatch, and then the cover from the bottom.

- Twin Pole Breaker 1 has two 20 Amp circuits to manage the two left rear 120V GFCI's and the thermostat
  - left circuit manages the top-left rear outlet
  - right circuit manages the bottom-left rear outlet and thermostat
- Twin Pole Breaker 2 has two 20 Amp circuits to manage the two right rear 120V GFCI's and the 2-gang outlet below the Load Center
  - left circuit manages the top-right rear outlet
  - right circuit manages the 2-gang outlet and the bottom-right rear outlet
- 2-Pole Breaker 3-4 manages the left 50 Amp twist lock receptacle (outlet)
- 2-Pole Breaker 5-6 manages the right 50 Amp twist lock receptacle (outlet)



**Figure 7**  
100 Amp Load Center

### 3.4 Inverters

See Section 4.

### 3.5 The Charge Controller

The Charge Controller (Fig. 8) protects the battery from reverse current and from overcharge, which lengthens its life. **The Charge Controller is pre-configured for optimal use, and does not require further programming.** The integrated MidNite Graphics Panel (MNGP) is the primary interface. (Fig. 9)

The Charge Controller has some helpful safety features including the GFP (Ground Fault Protection) and AFD (Arc Fault Detector). When one or more faults are detected the Charge Controller will stop outputting power and display a fault message in the bottom right corner of the home screen (STATUS).



**Figure 8**  
Charge Controller

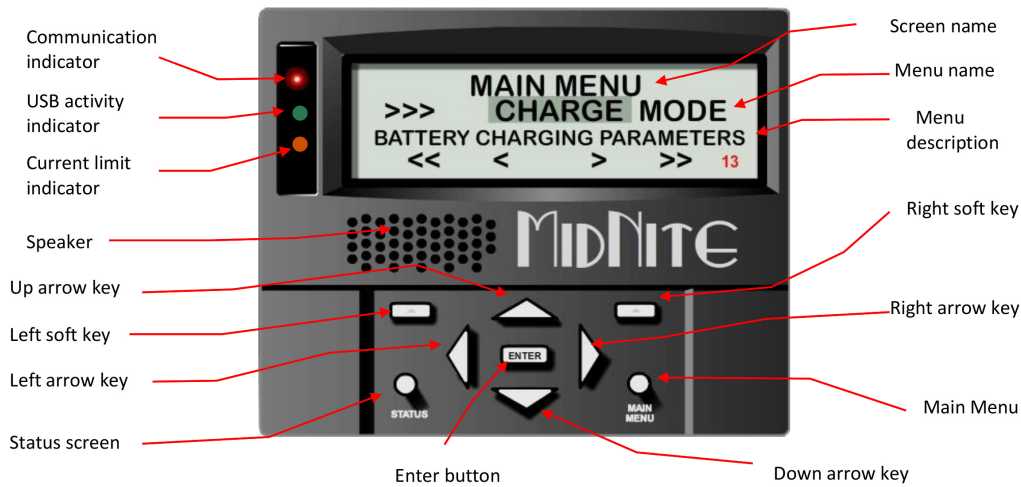

**Figure 9**

MidNite Graphics Panel (MNGP)

Main Menu:

<<CHARGE – MODE – AUX – MISC – LOGS – TWEAKS – TEMPS – NET>>

#### Commissioning (Quick Set)

Upon power-up, the Charge Controller should enter the Quick Set screen. If it does not, or you want to restore to factory default, proceed as follows:

1. With power off to the Controller, hold down the left and right arrow keys.
2. Continue to hold down the arrow buttons as you turn on the power and wait for the setup screen.
3. Answer the questions on-screen to complete the Quick Set.

## Menus and MNGP Features

Use the left and right arrow buttons to navigate the Charge Controller menus (See Table 1); below each menu option you will see an arrow with a description of the menu inside. Pushing <ENTER> will show the sub-menus of a highlighted menu; highlighting a sub-menu and pushing <ENTER> will take you into the main menu. The UP and DOWN arrow keys will take you out of the sub-menus one at a time.



*Push <MAIN MENU> or <STATUS> to return to the respective screen. The top right and left “soft keys” allow you to jump to one end of the main menu or the other.*

For example, to adjust the display settings (e.g. contrast, backlight, and volume):

1. Push the Main Menu button, then scroll to highlight “Misc” and press the <ENTER> button.
2. Use the left and right arrow keys to select a setting to change and press <ENTER>.
3. Press the up and down buttons to adjust, and press <ENTER> to save.

## Accessing Charge Controller Wiring



**There is a cable connecting the cover to the electronics. Do not pull hard or fast as damage could occur.**

To gain access to the wiring compartment, the front cover must be removed. Use a #2 Phillips screwdriver to remove the four screws from the cover, then unplug the display cable in order to lift the front half of the casting off. To re-install the front cover of the Charge Controller, plug in the display cable and carefully route it around the components on the circuit board as you set and then screw the cover in place.



*Do not force or screw in the cover if it does not sit into place easily. Stop and look for any interfering cables or wires, and carefully re-route them if necessary.*

## DC GFP (Ground Fault Protection)

Since 2008, the National Electronic Code (NEC) requires DC Ground Fault Protection (DC-GFP) on all photovoltaic (PV) systems in the USA. When the DC-GFP detects a fault between the *battery/PV negative* and *earth ground*, it turns off the charge ability and sounds a loud warning. The Charge Controller has internal DC-GFP built in which meets NEC requirements. (Fig. 10)

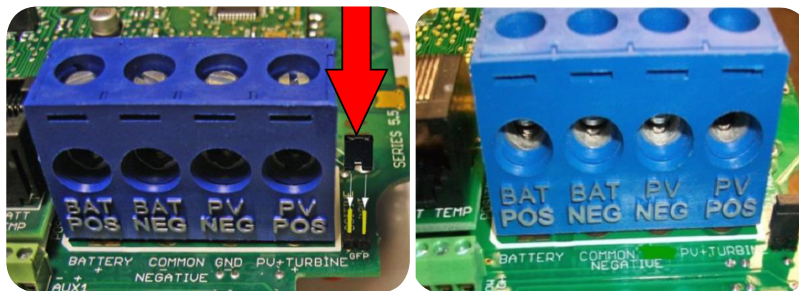

**Figure 10**

PTC and Ground Fault Protection

Table 1 MidNite Solar Menu Map

### Classic Menu Items

Status, Charge, Mode, Aux, Misc, Logs, Tweaks, Temps and Net

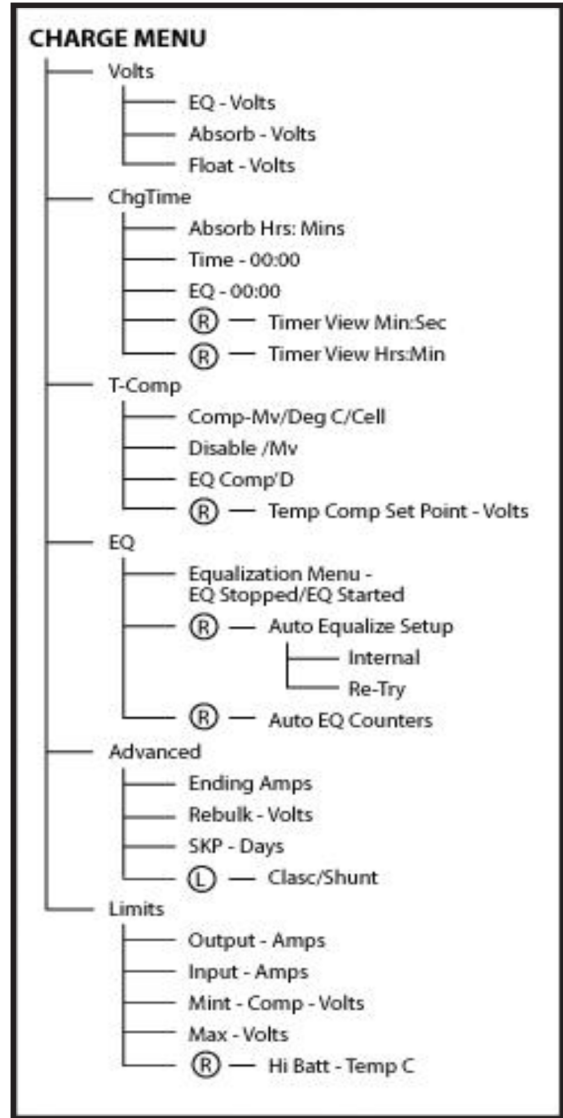
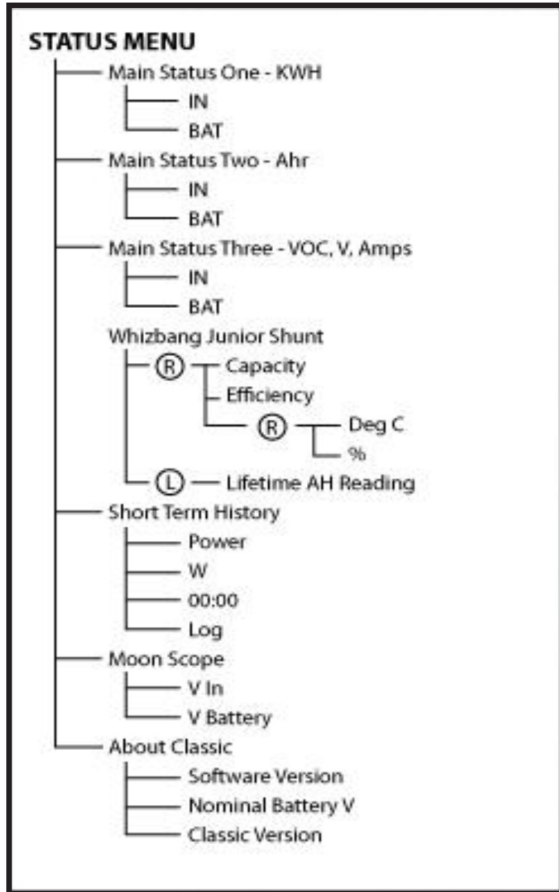

- (R) Symbolizes pushing the Right Soft Key
- (L) Symbolizes pushing the Left Soft Key

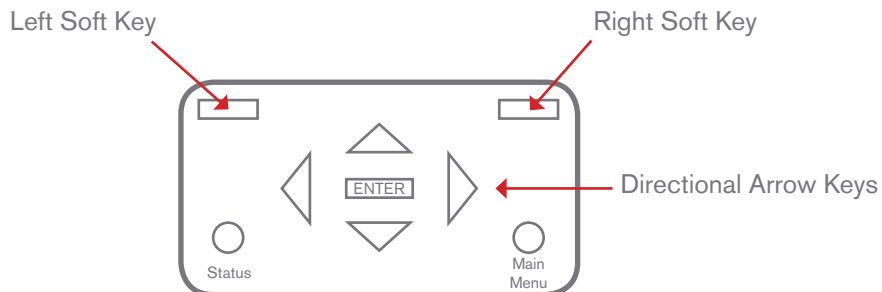

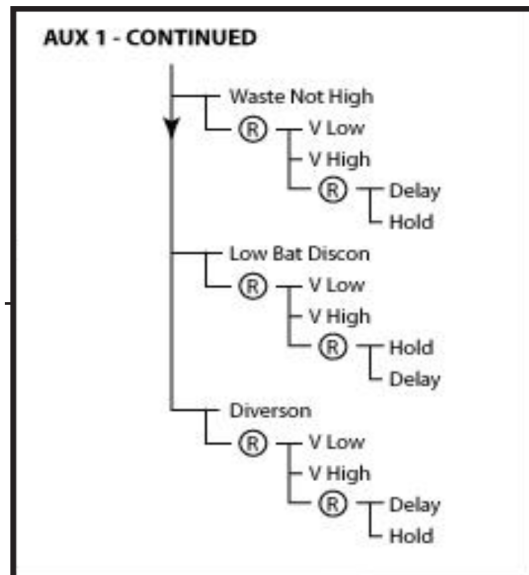
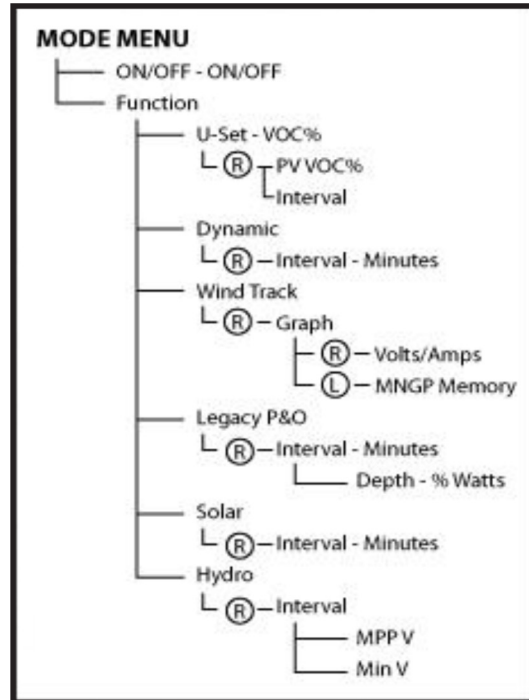
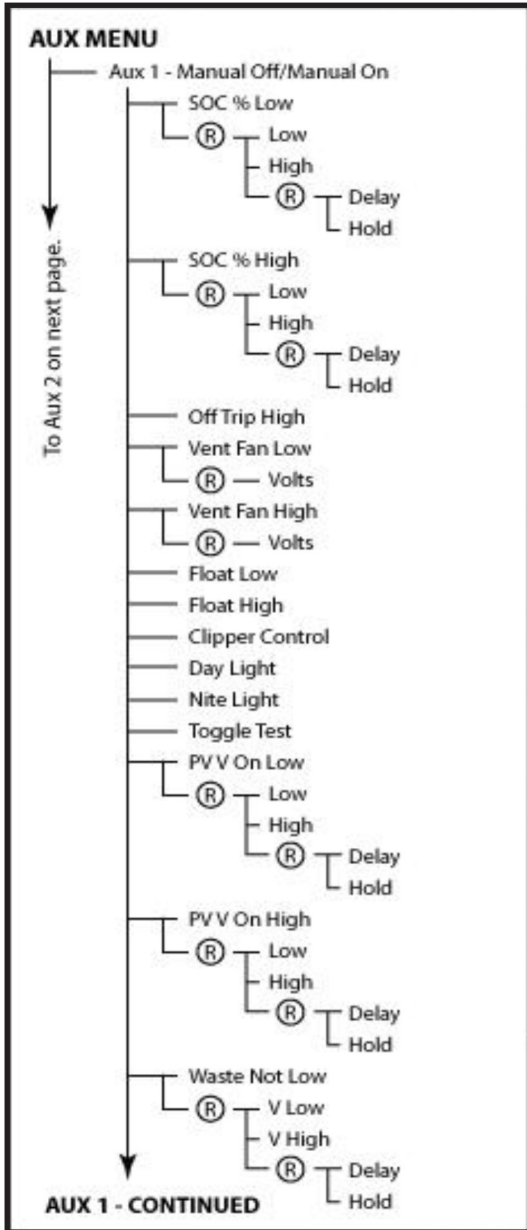

Continued from previous page.

### AUX MENU

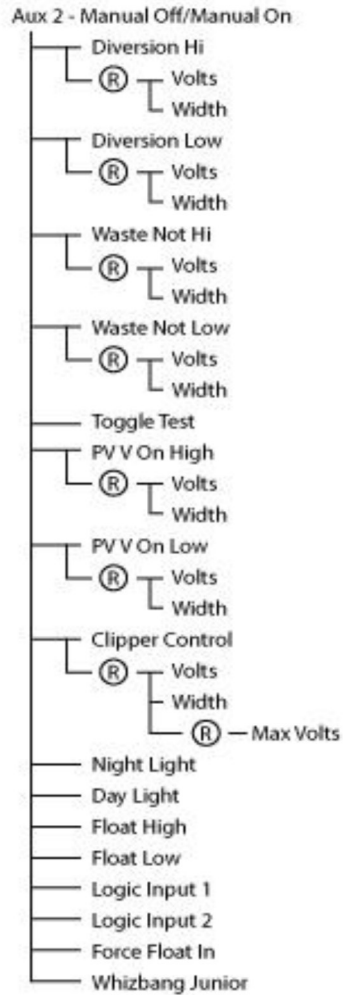

### MISC MENU

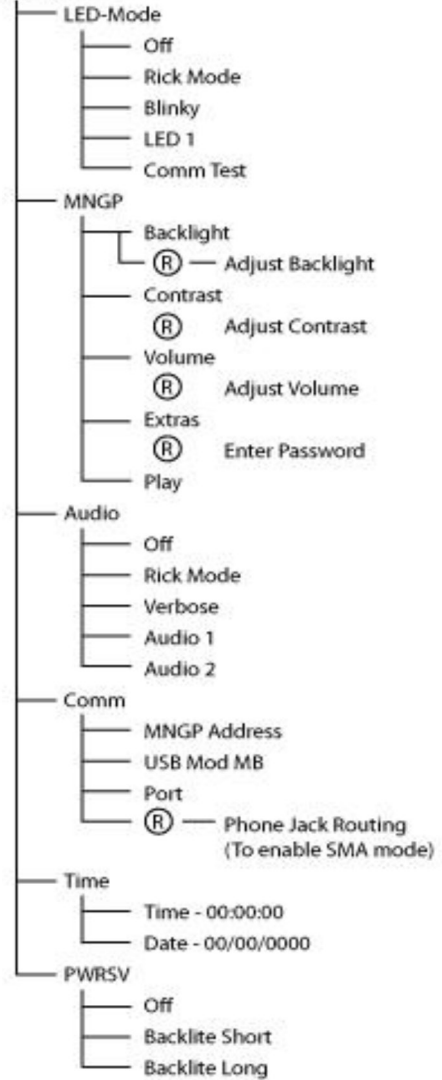

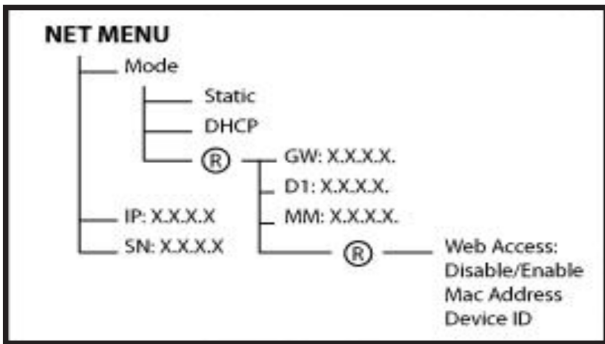
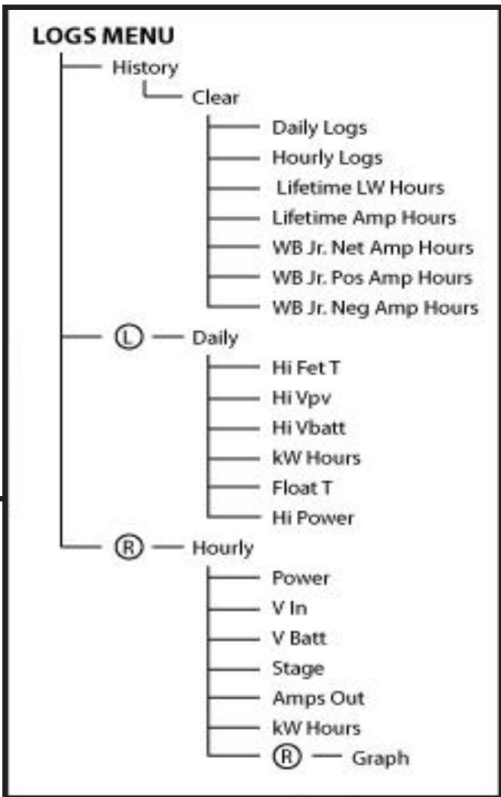
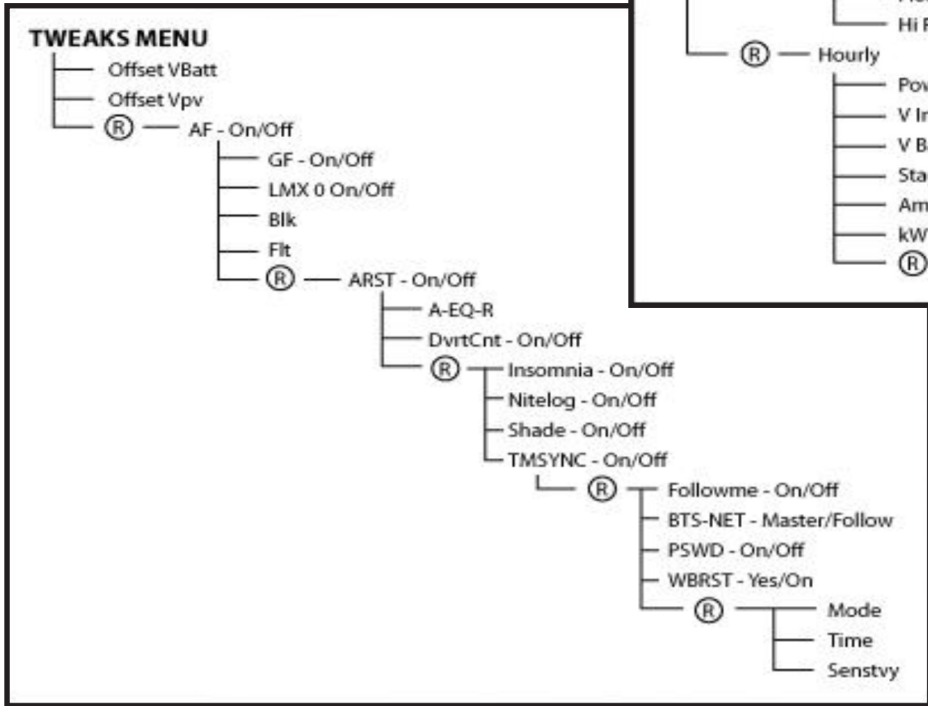

The ground fault protection device is simple to understand and use. The Charge Controller's system monitors a "self-healing" fuse (a PTC) between the *Negative* and *Ground* electrodes. The PTC opens when current exceeds its rating, signalling the Controller to stop charging, then closes again when current drops below its rating, allowing charging to be restored when the fault is cleared.

Since the PTC is self-healing, there are no fuses to change. To reset GFP function, fix the actual ground fault, then turn the Charge Controller (via the external battery breaker) off and back on again.

Disabling GFP –The factory setting makes a DC negative to System Ground connection in the Charge Controller; the GFP function will need to be disabled for Positive ground or an ungrounded DC System. To disable the internal Ground Fault Protection function, the jumper labeled GFP should be removed and the GFP function should be disabled in the TWEAKS menu.



**The GFP feature should ONLY be disabled to operate the Charge Controller in an ungrounded power system or in systems where GFP is not required.**

1. From the Main Menu, scroll until "TWEAKS" is highlighted and press <ENTER>.
2. From TWEAKS, go to the "MORE" menu; in MORE, scroll until "GFP" is highlighted.
3. Use the up and down arrow keys to toggle between on and off, and press <ENTER> to save.

### Arc Fault Detector (AFD)

The Arc Fault Detector is a unique safety component included in every Charge Controller. The Charge Controller will detect both low and high-powered arcs, typically in under 100ms, and shut down with an audible and visible alert to announce that there is a problem in the PV side of the system. When an arc is detected, the Charge Controller must be manually cleared.

To reset the Arc Fault Detector after detection has occurred:

1. Find and fix the actual arcing wire, terminal, splice etc.
2. Completely power down the Charge Controller by switching OFF the DC source (PV) breaker and then switching OFF the external battery breaker.
3. After 15 seconds, switch back ON the battery breaker and then the DC source breaker.

The arc fault module has three adjustable parameters:

MODE is set to 1 by factory default and should stay that way unless instructed by MidNite Solar.

TIME is set to 4 by factory default, and controls the time-length of the arc to trip the AFD. There should never be a need to change this parameter (adjust sensitivity instead).

SENSITIVITY controls how sensitive the AFD is; factory default is 10 of 15 (1 is most sensitive).

**If you experience nuisance tripping you can increase the sensitivity one level at a time:**

1. From the Main Menu, scroll to "TWEAKS" and press <ENTER>.
2. In TWEAKS, press the right soft key to get to the BITS menu.
3. In BITS, press the right soft key to get to "ARCADJ".
4. In this menu, use the left and right keys to select the feature to adjust.
5. Use the up and down arrow keys to change the parameters.
6. Power cycle the Charge Controller so it reads the new settings:
  - Switch OFF the DC source breaker and then the external battery breaker.
  - Then switch ON the battery breaker followed by the DC source breaker.

## **3.6 Frequently Asked Questions**

**Q: I lost the registration, what do I do?**

Contact DC Solar Distribution for a replacement at (925) 203-1088.

**Q: I lost the Quick Start Instructions and now I don't know how to turn it on.**

Quick Start instructions can be found on the sticker inside the Enclosure door, or in Section 1 of this manual. You can also contact DC Solar Distribution for replacement.

**Q: How do I adjust the Charge Controller?**



**Do not make adjustments to the Charge Controller. They are delivered to the customer preset. Any adjustments could cause malfunctions of the equipment.**

**Q: Do all six breakers need to be in the "ON" position?**

If operating a hybrid Solar Eclipse, the first five breakers should be in the ON position for operation. If operating a light tower, all six breakers must be in the ON position for operation.



# Inverters



This section will cover:

- ✓ Safe Use of the Inverter
- ✓ Accessing the Menus and setting parameters
- ✓ Interpreting Errors and Failures
- ✓ Accessing an External Charge

## 4.1 Overview

The Inverter pulls DC Current from the Battery and changes DC into AC Current. In systems with several Inverters, slave devices must be started first and wait for commands from the master devices; in this “Single Point of Operation” setup, all system control goes through the master device. The keypad and display (Fig. 11) allow users to access and adjust the menus and parameters at the Master Inverter.

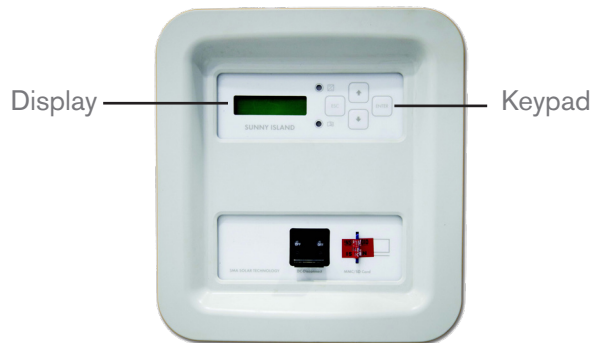

**Figure 11**  
Identifying Display and Keypad

### Display

The top line of the display shows the menu number and menu name or the name of the parameter, where applicable. The lower line shows symbols to indicate the Inverter status. A full description of symbols and characters is in § 4.4.



*Background illumination automatically shuts off after a short time of inactivity. Press any button to reactivate.*

### Keypad



Use <ENTER> to confirm an action, navigate one menu level down, or start/stop device (see § 4.2).



Use <ESC> to cancel a function, answer no, or to navigate one menu level higher.



Use the arrow keys to navigate through the current menu, or to increment or decrement a selected value.

## Menus

The “Home Screen” shows the main menu and operating modes, and will automatically display after more than five minutes of inactivity. The menus use a wrap-around arrangement allowing you to scroll directly from the last option to the first and vice versa. Some menu items and parameters are only accessible after entering the installer password.

## Breaker and SD card

The breaker (Fig. 12) is the main on/off switch for the Inverter, connecting it to DC power. It is located on front of the Inverter and labeled “DC Disconnect”.

The SD card (Fig. 12) maintains parameters and archives crucial data, allowing technicians to monitor problems with the unit. The SD CARD should never be removed unless authorized by DC Solar Distribution.

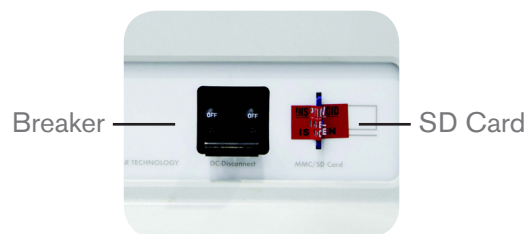
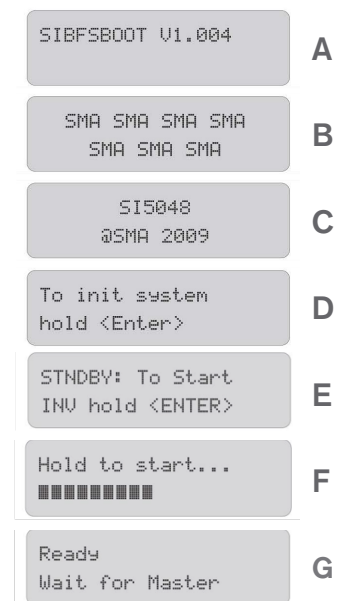

**Figure 12**  
Breaker and SD Card

## **4.2 Switching ON and OFF**

### Starting Inverters

1. Check that the electrical connections are correctly configured, matching voltages and polarities (from batteries to enclosure).
2. Switch the Slave Inverter's DC circuit breaker to the “ON” position. The Inverter display lights up and displays the notifications (A,B,C,D,G) shown to the right during start-up. When notification **G** (Fig. 13) is displayed, the start-up phase for the Slave Inverter has been completed.
3. Switch the Master Inverter's DC circuit breaker to the "ON" position. The Inverter display lights up and displays the notifications (A,B,C,D,E) shown to the right during start-up. When notification **E** (Fig. 13) is displayed, the start-up phase for the Master Inverter has been completed.
4. On the Master Inverter, Press <ENTER> and hold (display will show progress bar: **F**). On the Slave Inverter, notification **G** will show until the Master is started.



**Figure 13**  
Startup Notifications

5. When the Master Inverter beeps and the green LED turns on, the Inverter is operational. Both inverters will now display their main screens which are designated by an M for Master and an S for Slave.

### Stopping Inverters (Standby, Switching Off, and Disconnecting)

The following sequence will ensure that all internal values and counter positions are properly saved:

1. Press and hold <ESC>. The display will again show a progress bar.
2. The Inverter is now stopped and in Standby Mode. To turn off the Inverter entirely, switch the Inverter's DC circuit breaker to the "OFF" position.



*Even in standby mode the Inverter still requires approximately 4 watts of power from the battery.*



**Do not disconnect the Inverter from the battery unless instructed by DC Solar. If so directed, you must fully turn off the Inverters, disconnect the battery, and then wait at least 15 minutes before proceeding to allow the voltage inside the device to drop to a safe level.**

### Reactivating the Device Following Automatic Shutdown



*A complete shutdown indicates that component[s] for the off-grid power system have failed or are not working correctly, potentially due to incorrect parameter settings. Check the system for possible faults before and after reactivating in order to avoid unintended shutdowns in the future.*

To reactivate the Inverter after automatic shutdown due to a battery being too deeply discharged:

1. Switch the Inverter's DC circuit breaker to the "OFF" position.
2. Wait at least 15 minutes.
3. Switch the Inverter's DC circuit breaker to the "ON" position. The Inverter's display lights up. If the device cannot be turned back on after 15 minutes, wait another 30 minutes and try again. If you still cannot establish a connection, contact DC Solar.
4. Turn on the Inverter as described under "Starting Inverters".
5. Monitor the generator startup and check that the Inverter enters charge mode (see section 4.4 for symbol descriptions). After reactivation, it is important that the batteries be charged. If an auto-start generator is present, the Inverter should request the generator within a few minutes.
6. Check for proper functioning of all other solar generators in the system.

## **4.3 Menus and Parameters**

Menu Structure – See Table 2 (next page) for Menu Map.

**Table 2** Inverter Menu Hierarchy

**100# METERS**

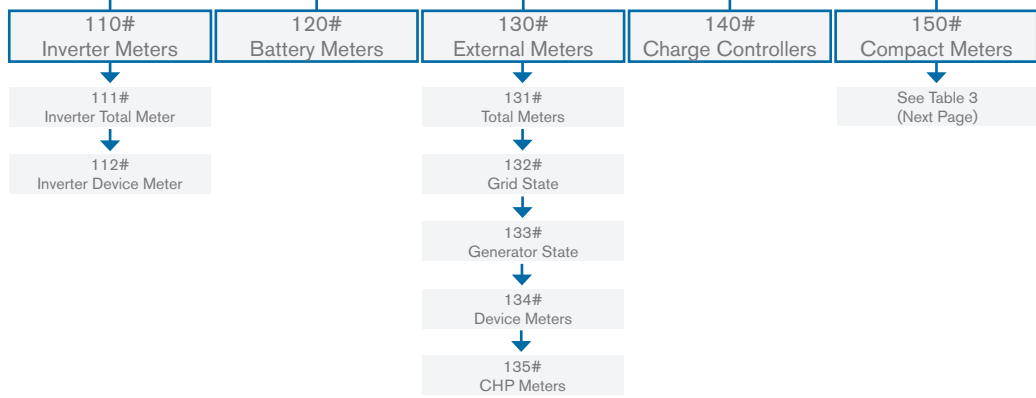

**200# SETTINGS**

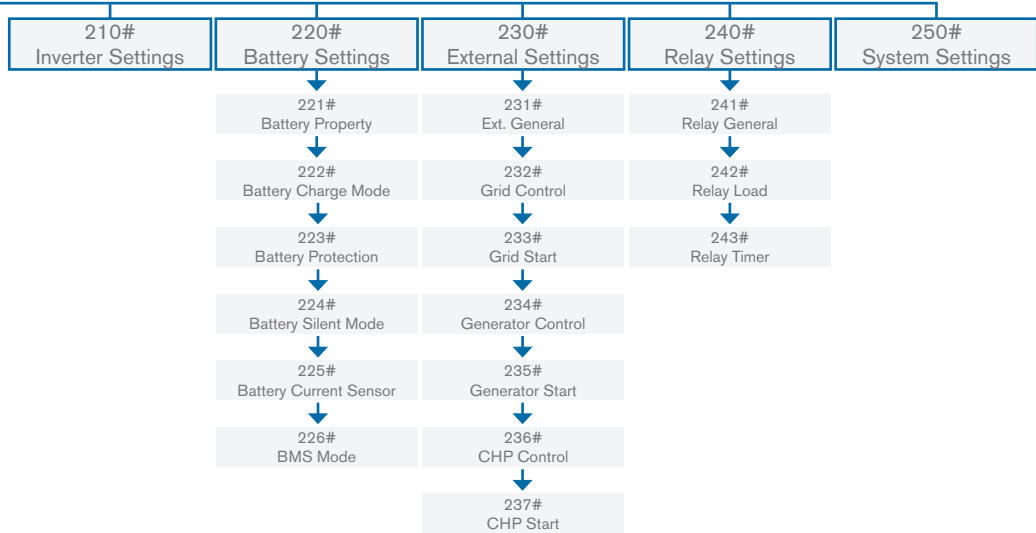

**300# DIAGNOSIS**

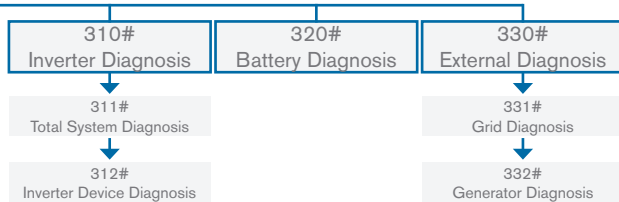

**400# FAILURE/EVENT**



**500# OPERATION**

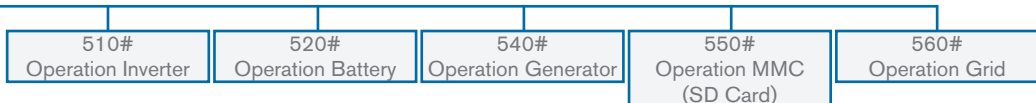

**600# DIRECT ACCESS**

Jump directly to parameter  
Select Name/Number:

**Table 3** Compact Meters

(Sub-menu 150#) provide information at-a-glance in the following areas:

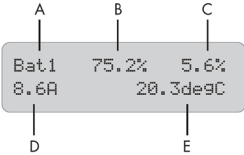
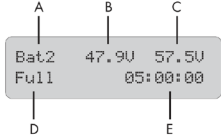
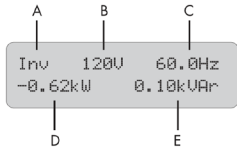
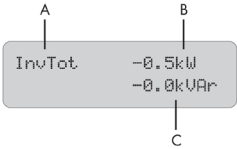
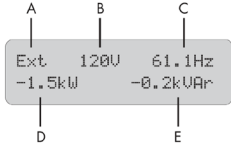
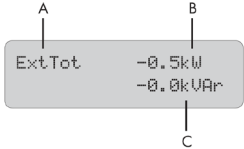
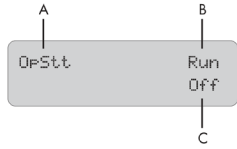
Bat1 (Battery Values, Set 1)	Position	Description
	A B C D E	Compact Meter Name Present battery charge state (BatSoc) Estimated error of the charge state (BatSocErr) Total Battery current of the cluster (TotBat Cur) Battery temperature (BatTmp)
Bat2 (Battery Values, Set 2)	Position	Description
	A B C D E	Compact Meter Name Battery voltage (BatVtg) Nominal value of charging voltage (BatChrgVtg) Active charging process (BatChrgOp) Remaining absorption time (AmptTmRmg)
Inv (AC Values of Inverter)	Position	Description
	A B C D E	Compact Meter Name Battery voltage at the Inverter (InvVtg) Present frequency at the Inverter (InvFrq) Present active power of Inverter (InvPwrAt) Present reactive power at the inverter (InvPwrPt)
InvTot (total AC values of inverter)	Position	Description
	A B C	Compact Meter Name Total active power of the Inverter (cluster) Total reactive power of the Inverter (cluster)
Ext (AC values of external source)	Position	Description
	A B C D E	Compact Meter Name Voltage of the external source (ExtVtg) Frequency of the external source (ExtFrq) Active power of the external source (ExtPwrAt) Reactive power of the external source (ExtPwrPT)
ExtTot (total AC values of external source)	Position	Description
	A B C	Compact Meter Name Total active power of the ext. source (cluster) Total reactive power of the ext. source (cluster)
OpStt (Inverter and Generator Status)	Position	Description
	A B C	Compact Meter Name Operating state of the Inverter (InvOpStt) State of the generator (GnStt)

## Changing Parameters

Note that some parameters can only be changed when the device is in standby mode. The Inverter displays a corresponding message for parameters that can only be changed in standby mode or require a different password level. (Fig. 14)

Menu items and parameters that can only be changed by the installer will be shown with a gray background in the parameter list if you have not entered a correct password. To change other parameters, proceed as follows:

1. Navigate through the menu to view or change the desired parameter. An arrow next to the displayed value indicates that the parameter can be changed.
2. Press <ENTER>. The arrow should begin to blink.
3. Use the up and down arrow buttons to change the value of the parameter. The increment speed increases if you hold the button pressed down.
4. Press <ENTER> to select a new value, then select Y (yes) or N (no) by pressing the up/down arrow buttons to accept or reject the changes.
5. Finally, press <ENTER> again to finish the process and continue with other modifications.

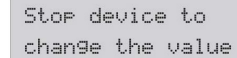

Stop device to  
change the value

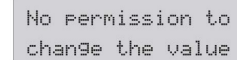

No permission to  
change the value

**Figure 14**

Permission Messages

## Entering the Installer Password



**Do not disclose the password to unauthorized persons. Dissemination of this information to other persons will lead to invalidation of all warranties.**

The Inverter allows you to enter the password not only in standby, but also during operation. The password is dependent on the operating hours counter. In the installer level there are extended access privileges to all necessary parameters.

To enter the installer password from the “Home Screen”:

1. Navigate to “200# Setting” menu, then “280# Password Setting”.
2. The password is the sum of the digits of the operating hours.  
From the message shown to the right (“OnTmh 123456 h”):

$$1 + 2 + 3 + 4 + 5 + 6 = 21$$

3. Press <ENTER>, then use the arrows to input the password.
4. Confirm the password by pressing <ENTER>.



200# Settings

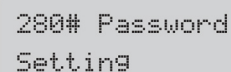

280# Password  
Setting



PW:\*\*\* Level[0]  
OnTmh 123456 h

**Figure 15**

Installer Password

“Level [1]” on the display (Fig. 15) means the installer operating level has been set. If the password is invalid, the Inverter remains at User Level [0]. Recalculate and re-enter the password as above.

The installer level is switched back to the user level if:

- An incorrect password is entered
- If no activity takes place within five minutes
- Specific parameters are entered that cause a restart
- The Inverter is switched off and on again

## 4.4 Display

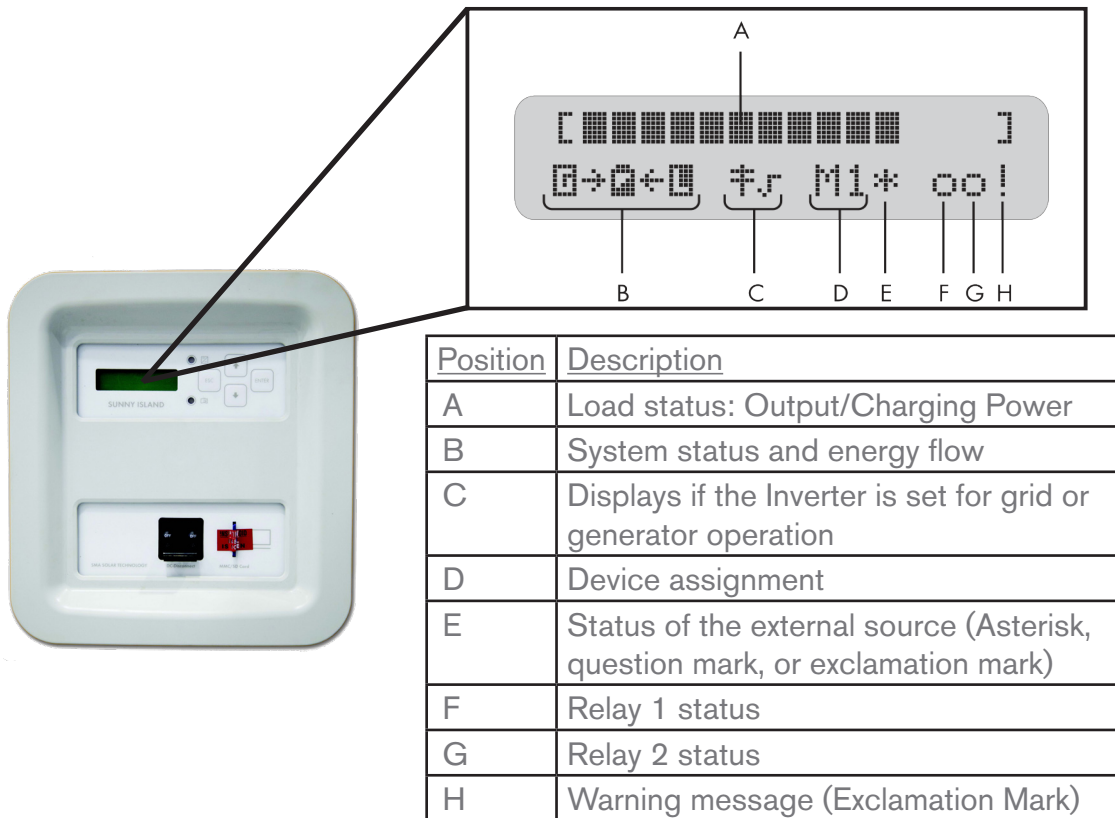

The display has two lines, each with 16 characters. The menu name and number is shown across the top line. The lower line has a series of symbols indicating the status of the Inverter. (See Fig. 16 and Table 4)



**Figure 16**  
Display of the Inverter

A selected parameter is displayed with the number first, then a separator (hash), and then the parameter name. The value, the unit, and the modification arrow (if applicable) are shown on the lower line.

**Table 4** Inverter symbols

Position	Symbol	Description
A	[ ]	Nominal power
	< >	Nominal load exceeded.
B	< , >	Direction of energy flow between grid/generator side, battery, and load side.
		Generator/grid side is on.
		Battery
C		Load side (Panels, appliances)
	‡	Utility pole
	‡√	The Inverter is working with grid limits.
D	‡x	The Inverter is working with generator limits.
	M1	The Inverter is configured as master.
E	S1	The inverter is configured as slave 1.
	*	Status of the external source: Voltage and frequency of the generator/grid are within set limits.
	?	Status of the external source: Voltage and frequency of the generator/grid are not within set limits. In this case, the Inverter does not connect the generator to the off-grid power system.
E	!	Status of the external source: The maximum admissible generator reverse power was exceeded; the Inverter has disconnected the generator from the off-grid power.
	B	"Battery" Request reason: Generator requested as a result of the battery charge level.
	C	"Cycle" Request reason: Generator requested via the generator operation's time-dependent repetition cycle (parameter: 235.17).
	E	"External" Request reason: Generator requested via the extension cluster. This request can only take place in multicluste
	L	Request reason "Load": Generator requested as a result of the load-dependent generator request.
	S	Request reason "Start": The generator has been requested by the operator manually setting the generator request in the Inverter from "Auto" to "Start." The generator is then no longer automatically controlled or switched off by the Inverter.
F/G	T	Request reason "Time": The generator was started for one hour using the "Run1h" setting in the Inverter. Once this time has passed, the Inverter automatically switches off the generator.
	o, ●	Solid circle = the relay is activated. Empty circle = the relay is deactivated.
H	!	Warning message is displayed: This symbol blinks until you have the warning or the error in the menu "#410 Failures Current" or "#420 Failure History".

In the Home Screen, the Inverter also shows the following parameters (name and values) in 3-second intervals in the upper line:

- Bar graph for output power or charging power (lower line shows the energy flow)
- Total active power of the inverter (cluster)
- Active power of external source (all phases)
- Present state of charge of the battery (SOC)
- Time remaining, according to priority
  - Absorption time
  - Generator warm-up time
  - Run 1h (Generator) time
  - Timer 1
  - Timer 2
- Active charging process

If, for example, the display changes every 3 seconds from “\*” to “B”, this means that the generator voltage and frequency lie within the specified limits and the generator was requested as a result of the battery charge level.



*The display shows only values relevant to the actual system status. If there is no generator connected or it was manually stopped, no generator values are displayed (field remains empty).*



*If a fault occurs, the device switches into standby mode and shows the fault on the display. The fault must be eliminated and confirmed, then the Inverter will carry out an autostart.*

### LED Indicators

- The GREEN LED indicates the inverter is in operation or standby.
- The RED LED indicates a disturbance or fault.
- Both the RED and GREEN LEDs light simultaneously during initialization.

## **4.5 Events, Warnings, and Failures**

The Inverter distinguishes between events and errors. "Events" describe state changes (e.g. generator connection); "errors" describe states not permitted past a certain rate (includes warnings and failures).

## Display of Events and Errors

The 400# menus show lists of events and errors in two-second intervals: the upper line shows a running count and the date and time of occurrence; the lower line shows the ID number and a short text description. (Fig.17)

A “!” on the right in the upper line indicates when a warning and/or failure occurred; a “C” designates viewing when the error was cleared. (Fig. 18)



For Direct Access to the Error List, press <ESC> and the arrow up button simultaneously to go directly to #420 Failure History.

```
001 11:55:01
E108 -----
```

```
001 10.08.2009
Silent
```

**Figure 17**  
Display of Events

```
001 11:55:01 C
F208 Warning
```

**Figure 18**  
Display of warnings  
and failures

## Error and Event Codes

Each error or event has a unique three-digit display number created according to the parameter/measuring value assignment. The event and failure codes have an identical numerical range (Table 5).

**Table 5** Error and Event Categories

Range	Abbreviation	System
1XX	INV	Inverter
2XX	BAT	Battery
3XX	EXT	External
4XX	GEN	Generator
5XX	GRD	Grid
6XX	REL/RLY	Relay
7XX	SYS	System
8XX	AUX	External Components

Errors are also categorized according to severity:

- Level 1. Warning: Home Screen shows notification that a warning was recorded; device continues to run.
- Level 2. Malfunction 1: Failure that can only be detected during operation; causes device to switch off, but it can be restarted immediately (autostart).

- Level 3. Malfunction 2: Failure that can also be detected in standby mode; causes device to switch off, and cannot be restarted (autostart) until the system detects the malfunction has ended.
- Level 4. Failure: Causes shutoff and requires troubleshooting, error confirmation, and manual restart.
- Level 5. Defect: Causes shutoff and permanently inhibits restart. Device must be replaced.

### Failure Confirmation

If there is a disturbance or failure, the Inverter goes into standby. Proceed as follows to confirm a failure:

1. Remove the cause. (See Table 5 for codes)
2. Confirm error has been cleared with <ENTER>.
3. Start the Inverter again.

### Handling Pending Failures during the Booting Procedures

During the booting procedure, pending failures are generally cleared without being entered into the history. After the booting procedure, a still-pending failure will be re-entered, and a failure the system detects to have stopped is entered as no longer being present in the list of errors.

## **4.6 Generator Management: See Section 6.1**

The Inverter monitors generator output and synchronizes power if voltage and frequency are within range. For electrically controlled generators, the Inverter manages generator operation via the GnReq signal according to programmed settings. Use menus 130# and 150# for monitoring, 230# and 540# for operation programming and control, and #330 for diagnosis. See Section 6.1 for full details.

## **4.7 Frequently Asked Questions**

**Q: Can I remove the SD card?**



**Never remove SD card. Removal of SD could harm the integrity of device. Only qualified technicians are allowed to remove.**

**Q: The SD card has been removed and is missing, what do I do?**

Contact DC Solar Distribution immediately (925) 203-1088.

**Q: What if I flipped down the breaker but forgot to Press and Hold <ENTER>? (step #7 “Shutting Down” on the Quick Start Guide)**



**Do not repeat this mistake! It is not necessary to reboot the system, but stopping the Inverter before switching OFF the breaker is an important safety measure for the device.**

**Q: The Inverter screen is blank, what do I do?**

- Try pressing <ENTER> on the Keypad. (The display may be in sleep mode)
- Verify that the breaker is in the “ON” position, and that the battery is plugged into the inverter. If not, plug in the battery and retry the start-up procedure.
- If the Inverter screen is still blank, the battery may need to recharge. Switch the breaker “OFF”, then wait 15 minutes and retry powering-on procedures. Repeat if necessary.

**Q: The Inverter screen asked me for a password, what’s the password for the inverter?**



**Password protected portions of the Inverter are for DC Solar Distribution technicians’ use only. Contact DC Solar Distribution for assistance (925) 203-1088.**

**Q: The display has a flashing exclamation point (!), what does this mean?**

An error warning has occurred.

**Q: How do I find the error code?**

From the Home Screen, go to menu #400 Events, then to #410 Failures Current; this menu will display any current errors (e.g. Fig. 19)

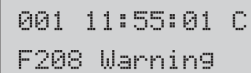

```
001 11:55:01 C
F208 Warning
```

**Figure 19**  
Error Code Display

**Q: How do I know how much power I am drawing?**

From the home screen, go to #100 meters, then to 150# Compact meters; look for the amperage draw in the lower-left corner of the "Bat1" compact meter.

**Table 6** Warning and Failures Codes

“F” marks a failure; “W” marks a warning

Display	Level	Description
F109	3	Transformer over temperature
F113	3	Over temperature on heat sink
F117	2	AC current limit (short-circuit control active for too long)
F121	3	Inverter overvoltage
W137	1	Derating due to temperature (heat sink or transformer)
F141	2	Inverter under voltage
F158	2	Voltage on output AC1
F201	2	Measuring range of battery voltage exceeded
F206	3	Battery over temperature
F208	3	Battery overvoltage error
W209	1	Battery overvoltage error
W210	1	Battery overvoltage warning
W211	1	Low battery temperature warning
W212	1	High battery temperature warning
W220	1	Warning SOH < 70 %
W309	1	Relay Protection
F314	2	External voltage failure
W315	1	Grid/generator disconnection due to insufficient external voltage
W319	1	Grid/generator disconnection due to excessive external voltage
W323	1	Grid/generator disconnection due to insufficient external frequency
W327	1	Grid/generator disconnection due to excessive external frequency
W331	1	Grid/generator disconnection due to islanding
W335	1	Disconnection from grid/generator due to violation of voltage limits (redundant measurement)
W339	1	Grid/generator disconnection due to voltage rise protection
W343	1	Disconnection from the external source, because the relation of the external voltage to the battery voltage is too high.
W347	1	Disconnection from external source due to excessive load
W351	1	Disconnection from external source due to external short-circuit
W401	1	Reverse power protection (generator)
W501	1	Grid reverse current prevented (quick grid disconnection)
F605	4	Transfer relay does not open
F702	5	DSP reset
F703	2	Timeout during a task
F704	4	Invalid DSP calibration
W705	1	DSP watchdog has been triggered
F706	4	Watchdog meter has expired (watchdog triggered several times in succession)
F710	4	Auto-start meter has expired (several auto-starts in succession)
W713	1	Watchdog has been triggered
F716	2	Measuring range of battery voltage exceeded
F720	4	Short-circuit or cable break on transformer temperature sensor
F721	4	Short-circuit or cable break on heat sink temperature sensor
W722	1	Short-circuit battery temperature sensor
W723	1	Cable break on battery temperature sensor
F731	4	Error in the cluster configuration
F732	4	Error in the address assignment of the cluster devices
W738	1	Synchronization not successful
F739	3	Internal communication of the master is interrupted
F743	3	Internal CAN communication of the master is interrupted

Table 6 (Cont.) Warning and Failures Codes

Display	Level	Description
W753	1	Invalid system time
F754	2	Communication with Multicluster Box interrupted
W755	1	Battery Preservation Mode 1 (LBM)
W756	1	Battery Preservation Mode 2 (LBM)
W757	1	Battery Preservation Mode 3 (LBM)
W759	1	No output voltage measured from the main cluster
F782	4	Failure of the grid monitoring
F801	4	4 Plausibility check of the contactors in a Multicluster Box has failed
W804	1	Grid operation not possible
W805	1	Generator operation not possible
F806	4	Multicluster Box settings do not correspond to the software settings
W807	1	No valid line voltage with the requested grid operation
W808	1	Fault in contactor Q4
F809	4	Fault in contactor Q10 (load shedding)
F810	4	Error in 15 V supply of the Multicluster Box
F811	4	Error in 24 V supply of the Multicluster Box
W815	1	Fault in contactor Q5
F816	2	Fault in contactor Q7
F818	4	A phase is missing, Multicluster Box goes into "Failure" status
W851	1	Pole of battery connection is reversed or short-circuit on the Sunny
W852	1	Battery overvoltage Inverter Charger
W853	1	Overvoltage PV generator Inverter Charger
W854	1	No PV voltage or short-circuit on Inverter Charger 1
W855	1	Sensor error (or under temperature) on Inverter Charger 1
W856	1	Over temperature Inverter Charger 1
W857	1	No communication with Inverter Charger 1 for more than 24 h
W861	1	Pole of battery connection is reversed or short-circuit on the Inverter Charger 2
W862	1	Battery overvoltage Inverter Charger 2
W863	1	Overvoltage PV generator Inverter Charger 2
W864	1	No PV voltage or short-circuit on Inverter Charger 2
W865	1	1 Sensor error (or under temperature) on Inverter Charger 2
W867	1	No communication with Inverter Charger 2 for more than 24 h
W871	1	Pole of battery connection is reversed or short-circuit on the Inverter Charger 3
W872	1	Battery overvoltage Inverter Charger 3
W873	1	Overvoltage PV generator Inverter Charger 3
W874	1	No PV voltage or short-circuit on Inverter Charger 3
W875	1	Sensor error (or under temperature) on Inverter Charger 3
W876	1	Over temperature Inverter Charger 3
W877	1	No communication with Inverter Charger 3 for more than 24 h
W881	1	Pole of battery connection is reversed or short-circuit on the Inverter Charger 4
W882	1	Battery overvoltage Inverter Charger 4
W883	1	Overvoltage PV generator Inverter Charger 4
W884	1	No PV voltage or short-circuit on Inverter Charger
W885	1	Sensor error (or under temperature) on Inverter Charger
W886	1	Over temperature Inverter Charger 4
W887	1	No communication with Inverter Charger 4 for more than 24 h
F890	2	Fault at the external measuring point of the Multi cluster Box



# Batteries and Outlets



This section will cover:

- ✓ Reading battery status on the Charge Controller and the Master Inverter
- ✓ Availability of specific plugs and outlets across Solar Eclipse Models

## 5.1 Battery Charge Stages on the Charge Controller

The Charge Controller goes through up to four states when charging the batteries:

- In Bulk MPPT (Constant Current) mode, the Charge Controller puts out maximum current to charge the batteries up until they reach the absorb voltage set point.
- In Absorb (Constant Voltage) mode, the Charge Controller maintains the absorb set point voltage until the batteries are fully charged or it reaches Float stage. The Charge Controller is no longer putting out maximum current.

The absorb time is proportional to the bulk time. (i.e. the time to reach the absorb voltage)

- In Float mode (or cycle), battery voltage is held at the float voltage set point (displayed on screen). Float time can be changed by the user.
- In Resting mode, the display reads “Resting” because the Charge Controller is not charging batteries (typically due to low light). If the Charge Controller is resting and should not be, check the setting of “Aux2” or call a DC Solar Distribution technician.

The Equalization function deliberately overcharges the batteries in order to bring all cells to an equal voltage and, ideally, return each to its optimum condition. This occurs only when enabled by the user.



*If a non-self-regulating solar array is connected to lead acid batteries with no overcharge protection, the life of your batteries will be compromised.*



Simple charge controllers contain a transistor that shunts the PV charging circuit, terminating the charging process at a pre-set high voltage. Once a pre-set low voltage is reached, the transistor "opens" the shunt, allowing charging to resume.

## 5.2 Battery Metering on the Inverter

From the home screen, navigate to 100# METERS, then 150# Compact Meters. "Bat1" shows percentage charge with estimated error, the total battery cluster current, and temperature. "Bat2" shows battery voltage, nominal charging voltage, the present charging process, and remaining absorption time. See Section 4 for full details.

## 5.3 Non-PV Battery Charge

The SB Industrial Connector (Fig. 20) is located on the external rear, right side of the Enclosure, and can be used for supplemental power or an alternative method for battery charging. It takes about 4.5 hours to fully recharge the batteries from a 15% state of charge via the SB Connector, or 1.3 hours from a 75% state of charge.



*To use an external (non PV) charge, the Inverter breaker needs to be switched "ON", and the display must be in standby mode.*



**Figure 20**

SB Industrial Connector

## 5.4 Outlets

### SCT20 Models

All Solar Eclipse SCT20 Models come equipped with the following outlets, at minimum:

- One 20A – 120VAC outlet
- Five 20A – 120VAC-GFCI outlets
- Two 50A – 120/240VAC outlets



**Figure 21**

Outlets



*The 20A outlets are located on the rear exterior and the interior of the Enclosure; the 50A outlets are located on the exterior left(Fig. 21); the SB Connector is located on the exterior right side. (Fig. 20)*

## Spider Box

Spider Boxes are not standard, but can be used on all units via the 50Amp Twist Lock outlets. Spider Boxes come equipped with the following:

- Six 20A – 120VAC-GFCI outlets
- One 30A – 120/240VAC outlet
- One 50A – 120/240VAC outlet



**Figure 22**  
Spider Box

## 5.5 Frequently Asked Questions

### **Q: What kind of batteries does the Solar Eclipse use? Where are they located?**

The Solar Eclipse uses Flood Lead Acid (FLA) batteries, consisting of 24 cells at 2.1V/cell for a total of 50.4V, which are located at the center of the unit.

### **Q: How do I know how much battery power I have left?**

From the home screen on the Inverter, scroll to #100 meter (hit <ENTER>), then to 150# Compact Meters. Look for the percentage charge (with error) shown in the “Bat1” value set.

### **Q: Do the Inverter and the Charge Controller monitor the same battery characteristics?**

Yes, both monitor voltage. However, the Charge Controller monitors only the PV Amps charging back to the batteries; the Inverter monitors both the charging and the discharging of the batteries.

### **Q: What is the most efficient non-PV charge?**

The SB industrial Connector is the most efficient.

# Enhancements

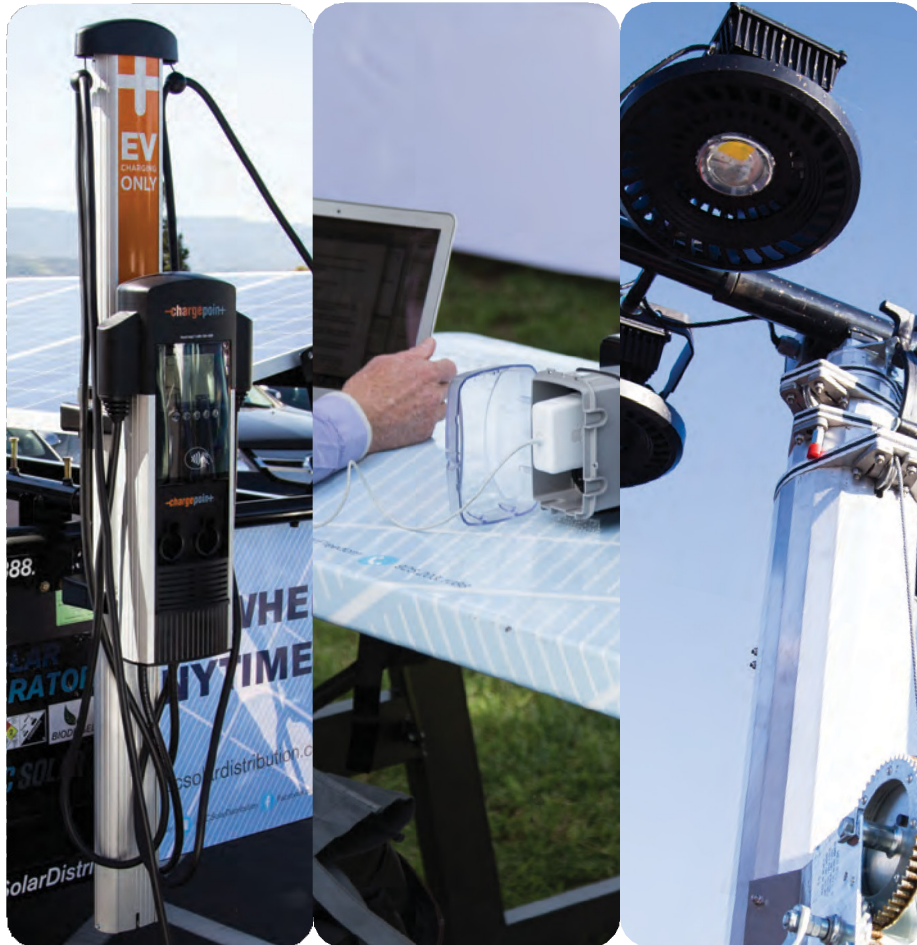

This section will cover:

- ✓ Management of External Generators for Hybrid units
- ✓ Deployment and Programming Instructions for Light Tower units
- ✓ Deployment Instructions for Electric Vehicle Charger units
- ✓ Deployment Instructions for Power Stations
- ✓ Important Safety Information regarding Fuel Cells

## 6.1 External Power Generator

The Solar Eclipse supports the integration of external sources of electric power through the AC2 connection in the Inverter. This section focuses on the operations and settings of an external diesel generator. For information on other connections, contact DC Solar.

### SCT20 Hybrid Series

Solar Eclipse Hybrid Models are equipped with a backup generator (Fig. 23), which automatically starts when the battery reaches a preset “low” level (50%), and automatically stops when the battery has been charged back up to a preset “safe” running capacity (95%).

DC Solar's SCT20 Hybrid series comes equipped with either a Kubota GL7000 or GL11000 generator. As of 2017, all Hybrids have been fitted standard with GL11000 generators.



*Adjusting the Inverter voltage and frequency parameters to integrate a different type of generator should only be done at the direction of a DC Solar technician.*



**Figure 23**  
Kubota Diesel Generator

For more detailed information about the maintenance and operations of the Kubota generator, please refer to the Kubota Operators's Manual provided with each Solar Eclipse Hybrid Model. If manual is not provided, a PDF version of this manual can be found online by searching “Kubota Lowboy 2 Operator's Manual” or directly at <[www.hardydiecel.com/kubota-generators/dl/lowboy-operator-manual.pdf](http://www.hardydiecel.com/kubota-generators/dl/lowboy-operator-manual.pdf)>.

The generator can be started and operated automatically by the Inverter or manually, according to the settings of the “234.07 GnStrMod” and “540.01 GnManSt” parameters.

## Operating Modes

<b>Auto:</b>	In this operating mode, the generator is automatically started according to the Inverter settings; triggers include state of charge or the user request for an equalization charge (“520.01 ChrgSelMan”).
<b>Run 1h:</b>	Operation for one hour. Once the lockout time has expired, the transition back into automatic mode follows.
<b>Start:</b>	Manual generator start - the generator runs “continuously” until stopped. The generator can only be manually stopped.
<b>Stop:</b>	The generator is manually stopped. The current generator request is cancelled - immediate disconnection from generator and change to lock state. Once the lockout time has ended, the generator switches into the automatic operation.

## Autostart

Autostart generators have a separate internal controller for the start procedures and can be directly integrated with the Solar Eclipse. The Inverter signals to start the generator (GNReq), synchronizes and connects following the warm-up time if the voltage and frequency are within the set limits. The Inverter keeps the request active until a disconnection is made and the shut-off delay time set has expired.

The Inverter has predefined settings to determine when the generator starts and how long it runs, according to battery charge or power loads. The automatic operating mode is set when GnAutoEna=On. The user can also manually start and stop the generator, if required.



*Manual inputs on the Inverter have a higher priority than automatic operation. If the Inverter is manually stopped while in automatic operating mode, it will enter the Stop/Lock mode, then return to automatic operation after the lock time (or the “540.02 GnAck” parameter confirmed).*

## Run Procedure

1. Warm-Up: If the generator is started (or detected, for manual operation) at the Inverter, the warm-up phase begins; the time for this is set at “234.12 GnWarmTm”. If the voltage and frequency detected fall out of the permissible range during this time, the warm-up timer restarts.



*If the generator cannot be connected within two minutes past twice the warmup time, the connection process is cancelled and a new attempt is made. After three attempts, the system changes to error state (“GnNoSync”).*

2. If the generator has been connected, the minimum run time begins (set at “234.08 GnOpTmMin”). The generator remains connected during this time, even if in the generator request stops.



*If a generator fault (e.g. generator failure) is detected, the generator is disconnected and then stopped immediately. The shut-off delay time is skipped and the generator enters the error state.*

3. If there is no generator request at the end of the minimum run time, the generator disconnects and enters the shut-off delay phase (Cool; time set at “234.10 GnCoolTm”).
4. The generator is stopped after the cool time. Once the stop time (“234.09 GnStpTm-0Min”) has elapsed, the generator is ready for the next request.



*Any internal generator request is suppressed and ignored during the shut-off delay time, during the stop time, or when the generator is in error/lock state.*



*If a generator fault is detected several times and the allowed number of attempted autostarts (“235.02 GnAutoStr”) has been exceeded, the system changes to the locked error state for the time set at “234.11 GnErrStpTm”. Afterwards, the generator is ready for another attempt. The Autostart counter is only reset after the generator has been successfully connected and the minimum run time has expired or when the locked error state (FailLock) is disabled.*

## Time Remaining

The remaining time of the generator meter (“133.03 GnRmgTm”) is displayed according to the current request or the phase of the generator state machine. The following times are displayed:

- Remaining run time during the warm-up phase (Warm)
- Remaining minimum run time in operation (Run/Run 1h)
- Remaining run time during the shut-off delay time (Cool)
- Remaining stop time after the shut-off delay time has expired (Lock)
- Remaining time in the error state (Fail)
- Remaining time in the locked error state (FailLock)

If the generator was started via the Inverter (automatically or manually) it can be stopped remotely at any time by using the “540.01 GnManStr” parameter to disconnect the generator; this process ignores the minimum run time and skips the shut-off delay time. Afterwards, the system enters the stop time (Lock). Stopping the Inverter has the same effect, but this will not stop a manual-only generator.



*To prevent autostart after manually stopping the generator, set “235.01 GnAutoEna” to “OFF”.*

## Manual Operation

For generators without a remote starting option, the Inverter can only monitor the generator input. If the Inverter detects generator voltage and frequency are within the set limits, the device will be synchronized and connected following the warm-up time. The Inverter and Charge Controller behavior will still be dictated by the programmed parameters, but when the Inverter disconnects a manual-start generator, the generator still needs to be stopped manually.

**The Inverter will automatically disconnect a stopped generator.**

Manual operating modes for generator management are triggered by the “540.01 GnManSt” parameter.

## Faults and Failures

Reverse Power – The Inverter can generate “reverse power”; to protect the generator, if the reverse power is above the set limit (“234.13 GnRvPwr”) for more than the set time (“234.14 GnRvTm”), the generator is disconnected and stopped. The shutoff delay time is skipped and the system enters the Lock mode, and connection is blocked for at least “231.03 ExtLkTm” or “234.09 GnStpTmMin”.

Generator Phase Failure – When a phase failure (e.g. broken fuse) is detected on a slave inverter, the device disconnects this phase. If the phase is detected as being available again, it is reconnected after the warm-up time “234.12 GnWarmTm” has elapsed. If the phase failure occurs on the master device, the generator is disconnected immediately. The system locks for the minimum stop time (Lock).

## 6.2 Light Tower

DC Solar's SCT20-Light Tower pairs the Solar Eclipse with dual mast lighting at the front and rear of the trailer. The masts are manufactured by U.S. Tower Corp to fit DC Solar specified requirements.

The lights can be programmed to turn on and off via the timer boxes located inside the Enclosure, just below the Charge Controller and PV Combiner.

**Table 7** Light Tower Specs

120W LED Count	8
Emits	97,520 Lumens
Light Distribution	1-2 Acres
Lumens/Watt	102
Lens Material	Strengthened Glass
Rated Lights Life	50,000 h
Color Temp	4,000 K

### Setting up the Light Tower Masts

Read and understand all instructions before attempting to erect or maintain the towers.



*If you are not experienced with installations or repairs, contact a DC Solar Technician before proceeding.*

Deploying the Light Masts:

1. Ensure the area is clear for both the PV arrays and the light tower.



**Never position the towers near power lines.**

2. Before raising the tower, adjust the lights on each mast. They can be rotated independently, or as a group by loosening the threaded locking bin and rotating the light bar.

- Once the light bar has been adjusted to desired position, pull locking pin located at the bottom of the mast to rotate mast to desired position and replace locking pin.
- Using hand crank, raise mast to desired height while being mindful of any obstructions.



The work winch is capable of lifting 1,500 lbs. and should be operated with extreme caution.

- Once the system is activated, the lights can be toggled ON/OFF manually or with program timers.

Preparing for transport/storage:

- Once system is deactivated, use hand crank to lower mast.
- Pull locking pin to rotate mast so the crank faces the trailer front; replace the locking pin.
- Rotate the light bar to a flat position with the lights facing downward for travel.
- Secure lights with rubber strap.



## Warnings



If in doubt that any component is not functional or cannot safely be operated, DO NOT operate the unit, and contact DC Solar Distribution. The unit must be properly inspected and deemed to be in good working order before resuming normal operation.

Never attempt to free any jammed part yourself, contact a DC Solar Technician.

Inspect cables, cable attachments, pulleys or winch before each use. Cables must be replaced every three years.

Keep your head and limbs clear of sections and moving parts. In icy conditions, moving parts (e.g. cables, pulleys, winch) may not operate correctly; use extreme caution.

## Timer Boxes

The Solar Eclipse SCT20-HLT comes equipped with timers that allow for automatic control of when they turn on. Before proceeding, ensure that all the steps have been taken in the Quick Start Guide.

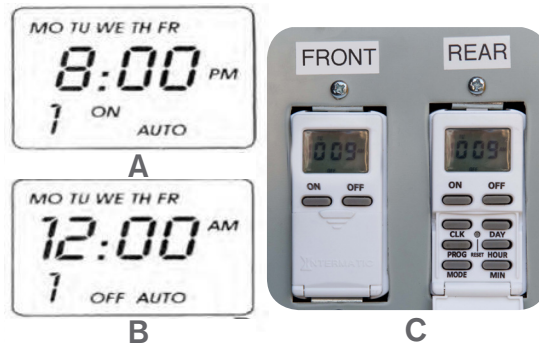

**Figure 24**  
Light Timer Box

To set the clock, hold down the "CLK" button, then use <DAY>, <HOUR>, and <MIN> to adjust time.

To Program events:

1. Press the "PROG" button once.



*The number in the lower left hand corner indicates the event being programmed. (See Fig. 24 A)*

2. Press the "DAY" button repeatedly to select day(s) for the lights to turn on. The options are:
  - Every day (MO TU WE TH FR)
  - Weekdays only (MO TU WE TH FR)
  - Weekends only (SA SU)
  - Individual days of the week (MO, etc.)
3. Use <HOUR> and <MIN> to set the lights ON time.
4. Press <PROG>, then set the OFF time, as above.
5. Press <PROG> to set additional events, if any.
6. Press <MODE> to select Auto/RDM/Manual mode.
  - AUTO will run scheduled events.
  - RDM will run scheduled events randomly.
  - A blank field represents manual operation only.

To review programmed events, press PROG repeatedly. When finished, press the CLK button to return the display to the time of day. To delete an event, press PROG to locate it; press and hold MODE and press PROG to clear the setting. If operational failure occurs, press RESET to clear all settings and restart the timer.



*The ON/OFF buttons will override the current programmed events.  
If the timer is set to AUTO mode, the next programmed event in the schedule will occur.*



**Figure 25**  
Light Towers in Use

## 6.3 Electric Vehicle Charger

The SCT20-EV pairs the Solar Eclipse SCT20 Hybrid with ChargePoint's CT 4023 (Level 2) charger, which charges at a maximum rate of 25 miles of range per hour. Interface instructions are available in English, French, and Spanish, and the capacitive buttons work in all weather conditions. (Fig. 26)



**Figure 26**

Electric Vehicle Charger

**Right:** Connecting EV Charger to the trailer  
**Left:** Replacing pintle hitch with holster

**Table 8** Charging Station Specifications



*A Clean Energy Company*



**CHARGING STATION SPECIFICATIONS**

**Electrical Input**

AC Power Input Rating – Standard	208/240 VAC 60hz single phase @ 32A x 2
AC Power Input Rating – Power Sharing	208/240 VAC 60Hz single phase @ 32A
Input Power Connections – Standard	Two independent 40A branch circuits
Input Power Connections – Power Sharing Required	One 40 branch circuit
Service Panel Breaker – Standard Required Service	40A dual pole (non-GFCI type) x 2
Panel Breaker – Power Sharing Service Panel GFCI	40A dual pole (non-GFCI type)
Wiring – Standard	Do not provide external GFCI as it may conflict with internal GFCI (CCID)
Wiring – Power Sharing	5-wire (L1, L1, L2, L2, Earth)
Station Power	3-wire (L1, L2, Earth)

**Electrical Output**

AC - Standard	7.2kW (240VAC @ 30A) x 2
AC - Power Sharing	7.2kW (240VAC @ 30A) x 1 OR 3.5kW (240VAC @ 16A) x 2

**Functional Interfaces**

Connector(s) Type	SAE J1772™ x 2
Charging Cable Length	18' (5.5 meters) x 2
Overhead Cable Management System LCD	Yes
Display	5.7" full color, 640 x 480, 30fps full motion video, active matrix, UV protected
Card Reader	ISO 15693, 14443, NFC
Locking Holster	Yes x 2

**Safety and Connectivity Features**

Ground Fault Detection Open Safety	20mA CCID with auto retry
Ground Detection Plug - Out Detection	Continuously monitors presence of safety (green wire) ground connection Power terminated per SAE J1772™ specifications
Power Measurement Accuracy	+/- 2% from 2% to full scale (32A)
Power Report/Store Interval Local	15 minute, aligned to hour
Area Network	2.4 GHz Wi-Fi (802.11 b/g/n)
Wide Area Network	3G GSM, 3G CDMA

**Safety and Operational Ratings**

Enclosure Rating	Type 3R per UL SOE
Safety Compliance	UL listed for USA and cUL certified for Canada; complies with UL 2594, UL 2231-1, UL 2231-2, and NEC Article 625
Surge Protection	6kV @ 3000A. In geographic areas subject to frequent thunder storms, supplemental surge protection at the service panel is recommended.
EMC Compliance	FCC Part 15 Class A
Operating Temperature	-22°F to 122°F (-30°C to +50°C)
Operating Humidity	Up to 85%@ +50°C (122°F) non-condensing
Non-Operating Humidity	Up to 95%@ +50°C (122°F) non-condensing
Terminal Block Temperature Rating	221°F (105°C)
Maximum Charging Stations per 802.11 Radio Group	10. Each station must be within 150' "line of sight" of a gateway station.

## Deploying the EV Charger

1. Remove the pintle hitch bolts (place hitch inside Enclosure) and use them to secure the deployment holster (found inside Enclosure) to the front of the trailer.
2. Remove security bolt from the transport holster (rear), then lift the charger off the foot plate and out of the transport holster and place it in the deployment receiver. Replace rear security bolt.



*Use proper lifting technique and seek assistance as necessary to avoid muscle strain, injury, or damage to the unit.*

3. Adjust the jack stand and deployment collar so the charger sits just above the ground, then rotate to the desired position and tighten the security bolt.
4. Unwrap the power cords and run them along the C-channel of the trailer tongue to plug into the 50 Amp outlets at the exterior left of the Enclosure, securing with zip-ties along the way.

Once system is activated, the EV Charger is ready for use.

## Preparing for transit/storage

1. Once the system is deactivated, unplug the charger from 50 Amp outlets. Remove any zip-ties and re-wrap the power cords on hangers, securing with zip-ties.
2. Remove the front and rear security bolts, then lift and move the charger from the deployment holster to the transport holster. Replace and tighten both security bolts.
3. Remove the pintle hitch bolts and place the deployment holster inside the Enclosure; return the pintle hitch to the front of the trailer and secure in place with the pintle hitch bolts.

## **6.4 Power Station**

The Power Station (Fig. 27) pairs the Solar Eclipse with a fully integrated work station equipped with 120VAC outlets in order to charge portable electronic devices.

**Table 9** Seating Area Specifications

120V 15-Amp Receptacles	4 / table
Outlets (2 per receptacle)	8 / table
Table with benches	up to 8 tables per unit
Deployed Dimensions	72" L x 56.5" W x 18.5" H

## Deploying the Power Station

1. Open and orient desired number of picnic tables around the unit (up to 8 per unit).
2. Mount plug boxes to tables using provided hardware. Secure the cables with zipties along the underside of the table (towards the trailer) and to the ground.

3. Run the cables along the ground and under the trailer, and plug them into the Spider Box or the cables can be plugged into the back of the enclosure
4. Place cable channel from the table to the trailer perimeter to avoid tripping hazard.
5. Reset the GFCIs before use, as needed.

### Preparing for Transit/Storage

1. Unplug all devices from the picnic tables and shut off system.
2. Remove and stow cable channel, then unplug cables from the Spider Box or from the receptacles in the back of the enclosure.
3. Cut zipties and coil cables, then un-mount plug boxes from tables.
4. Stow tables, plug boxes and cables.
5. Prepare trailer for transit/storage as described in previous sections.



**Figure 27**  
Power Station Deployed

## 6.5 Fuel Cell

With specifications from DC Solar, ECI Fuel Systems has manufactured a diesel fuel cell (Fig. 28) that comes standard on the Solar Eclipse Hybrid Models. The fuel cell meets NFPA 1192 requirements, as well as construction requirements for DOT/FMCSA 393.67 Section C.

ECI also manufactures a product which maintains annual certifications for your fuel system. This is to ensure continued compliance with both state and federal laws. ECI has conducted product testing while also meeting construction and accessory requirements to ensure your compliance with:

National Fire Protection Association (NFPA)  
Federal Motor Carrier Administration (FMSCA)  
Department of Transportation (DOT)  
Canadian Standards Association (CSA)

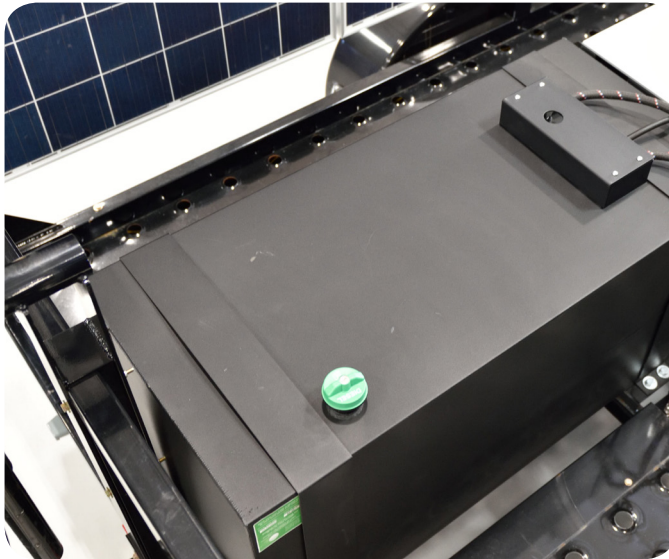

**Figure 28**  
Fuel Cell

ECI Fuel Systems



*Do not exceed 90% of tanks liquid capacity. Total tank capacity: 113 Gal. (427L)*

P/N: 4660-SG

# Maintenance



This section will cover:

- ✓ How to maintain the Solar Eclipse  
The Solar Eclipse requires relatively low maintenance; however, there are a few simple maintenance procedures that will ensure the longevity of the Solar Eclipse.

## 7.1 Trailer

Use super white, multi-purpose grease to lubricate the trailer's spring-loaded locking pins at least once per year (dry or dusty climates may require lubrication more often).  
Maintain trailer tires: tire pressure of 65psi; proper torque of 85 ft. lbs on tire lug nuts.

## 7.2 PV Arrays

Keep PV arrays free of dust and dirt for optimal use.



**Clean ONLY with WATER, soft bristle brush, towel and squeegee for cleaning. NEVER power wash, or use any soaps or chemicals; this will DAMAGE the solar panels and void the warranties.**

## 7.3 Inverter and Charge Controller

The Inverter's and Charge Controller's firmware may require periodic updates. DC Solar Distribution monitors these remotely and will contact the user when updates are needed.

## 7.4 Battery

There are 24 cells with water reservoirs on each battery. Every two months, (whether unit is in operation or storage) each reservoir should be filled with distilled water to 1/4 inch over the battery plate. (Fig. 29)



Figure 29

Filling battery reservoirs with battery filler (left two) or automatic shut-off water mule (right two)

## 7.5 Storage

For long-term storage outside, the unit should be left with the arrays deployed and the Inverter set to standby (breakers and Charge Controller should be left ON) to ensure the batteries remain charged.

If the unit is stored indoors, the system should be completely powered down (breakers switched OFF).

# Appendices

## 8.1 List of Figures

Figure 1	
Startup Inverter Display.....	2
Figure 2	
Stopping Inverter Display .....	3
Figure 3	
Arrays in position for transportation. ....	6
Figure 4	
Securing the Solar Eclipse For Transport.....	6
Figure 5	
Locating the locking pins.....	7
Figure 6	
PV Combiner Box.....	10
Figure 7	
100 Amp Load Center .....	11
Figure 8	
Charge Controller.....	12
Figure 9	
MidNite Graphics Panel (MNGP) .....	12
Figure 10	
PTC and Ground Fault Protection.....	13
Figure 11	
Identifying Display and Keypad .....	22
Figure 12	
Breaker and SD Card.....	23
Figure 13	
Startup Notifications.....	23
Figure 14	
Permission Messages.....	27
Figure 15	
Installer Password .....	27
Figure 16	
Display of the Inverter.....	28
Figure 17	
Display of Events .....	31
Figure 18	
Display of warnings and failures .....	31
Figure 19	
Error Code Display.....	33
Figure 20	
SB Industrial Connector .....	39

Figure 21	
Outlets .....	39
Figure 22	
Spider Box .....	40
Figure 23	
Kubota Diesel Generator .....	42
Figure 24	
Light Timer Box .....	46
Figure 25	
Light Towers in Use.....	47
Figure 26	
Electric Vehicle Charger .....	48
Figure 27	
Power Station Deployed.....	51
Figure 28	
Fuel Cell.....	52
Figure 29	
Filling battery reservoirs with battery filler (left two) or automatic shut-off water mule (right two).....	54

## 8.2 List of Tables and Diagrams

Table 1 MidNite Solar Menu Map .....	14
Table 2 Inverter Menu Hierarchy .....	25
Table 3 Compact Meters .....	26
Table 4 Inverter symbols .....	29
Table 5 Error and Event Categories .....	31
Table 6 Warning and Failures Codes .....	34
Table 7 Light Tower Specs.....	45
Table 8 Charging Station Specifications .....	49
Table 9 Seating Area Specifications.....	50
Table 10 Event Codes.....	63

## 8.3 Additional References

The Sunny Island Inverter (6048-US) Manual can be found at:

<<http://files.sma.de/dl/15216/SI4548-6048-US-BE-en-21W.pdf>>

A manual for the MidNite Charge Controller can be found at:

<[http://www.midnitesolar.com/pdfs/Classic\\_manual\\_REV\\_2056.pdf](http://www.midnitesolar.com/pdfs/Classic_manual_REV_2056.pdf)>

The Kubota GL11000 Manual can be found at:

<[www.hardydiesel.com/kubota-generators/dl/lowboy-operator-manual.pdf](http://www.hardydiesel.com/kubota-generators/dl/lowboy-operator-manual.pdf)>

Technical Information for the ChargePoint CT4023 can be found at:

<<https://www.chargepoint.com/files/datasheets/ds-ct4000.pdf>> and

<[https://www.chargepoint.com/files/CT4000\\_Install\\_Guide.pdf](https://www.chargepoint.com/files/CT4000_Install_Guide.pdf)>

## 8.4 Glossary

**100 Amp Load Center:** Circuit breaker for the Solar Eclipse outlets; sits left-center in the Enclosure.

**Absorption Phase (Constant voltage phase):** A charging phase using constant charging voltage. The charging current constantly decreases in this phase.

**Alternating Current (AC):** Electrical current which periodically reverses direction; contrast with Direct Current (DC). Typical form of commercial electricity. Also used to describe the voltage in an AC system.

**Ampere-hour (Ah):** Unit of electrical charge, one ampere-hour is the charge provided by a constant current of 1 A over a period of one hour.

**Arc Fault Detection (AFD):** A built-in safety feature of the Charge Controller. An arc fault is a high power discharge between conductors not connected by a wire; can trigger electrical fire.

**Battery Charge Mode:** Operating mode of the battery inverter in which the inverter takes energy from the AC grid to recharge the battery in a controlled way. In this operating mode, the battery inverter is responsible for correctly charging the batteries and acts like an independent battery charger.

**Battery Management (Inverter):** The battery management is responsible for optimum battery storage system charging and reliable protection against deep discharge. This is the only way of ensuring that the battery service life reflects the manufacturer's specifications.

**Battery:** An electrochemical energy storage that can release previously stored chemical energy as electrical energy. A distinction is made between non-rechargeable batteries (often used in end-customer markets) and rechargeable batteries (batteries). In stand-alone grid systems, lead-acid batteries are almost always used and, very rarely, nickel-cadmium batteries are used as secondary rechargeable batteries.

**Breakaway Cable:** Triggers stopping of the trailer if the trailer is separated from the towing vehicle.

**Capacity:** Describes the storage capability of a cell or battery, specified in Ah (ampere-hour). The capacity of a battery is heavily dependent on the charging cycle, the amount of electrical current strength drawn and the temperature.

**Charge Controller:** Regulates electrical charge flowing to and from the batteries, protecting them from overcharge, reverse current, and other faults, and executing equalization charges when requested.

Operating States: Bulk MPPT (const. current), Absorb (constant voltage), Float (or cycle), Resting

**Compact Meters (Inverter):** At-a-glance display of system data (Batteries, Inverters, External, Operating)

**Direct Current (DC):** Electrical current which flows in a single direction; contrast with Alternating Current (AC). Form of electrical power in batteries. Also used to describe voltage in a DC system.

**Electrolyte:** A chemical solution that allows the conduction of ions within a battery. In lead-acid batteries, the electrolyte is diluted sulfuric acid and is also a reactant in the electrochemical reaction. Nickel/cadmium batteries use an alkaline electrolyte (potassium hydroxide).

**Equalization Charge:** Allows different series-connected battery cells to be charged to a unified state of charge of 95% to 100%. Without regular equalization charge, the state of charge of the different cells slowly drift apart, which can lead to a poor battery power performance and a premature battery storage system failure.

**Errors (Inverter):** describe states that are not permitted or are only permitted up to a certain rate. This includes warnings, disturbances and failures. User interaction is generally required.

**Events (Inverter):** describe state changes or transient states (e.g. generator connection).

**Fast Charge:** Boost charge: serves to charge the battery as quickly and efficiently as possible to a state of charge of approx. 85% to 90%.

**Firmware:** is software that is stored in a chip in various electronic devices, such as Sunny Island, hard disk recorders, DVD burners and players, newer television sets, household appliances and computers — in contrast to software that is stored on a hard drive, CD-ROM or other media. These days, firmware is usually stored in Flash memory or an EEPROM chip.

**Float Charge (Maintenance charge):** Allows the batteries to be slowly charged to a state of charge of 100% without the negative effects of overcharging. Complete charging to 100% using float charge takes several days. For this reason, float charge is more important for battery-backup systems and less important for stand-alone grids.

**Flooded lead-acid (FLA) battery:** a lead-acid battery with liquid electrolyte.

**Full Charge:** Recharging of the batteries to a level of approximately 95% on a regular basis (at least once a month). This efficiently avoids premature aging of the batteries caused by inadequate charging.

**Generator Modes (Manual):** Auto, Run 1h, Start, Stop.

**Generator States:** Off, Initialize, Ready, Warm, Connect, Run, Retry, Disconnect, Cool, Lock, Fail, Faillock.

**Ground Fault Circuit Interrupter (GFCI):** A safety feature of outlets to stop current when it is detected to be flowing along an unintended path (e.g. water or a person).

**Ground Fault Protection (DC GFP):** A built-in safety feature of the Charge Controller. A Ground Fault is excessive current flow caused by contact between a live wire and grounded equipment.

**Inverter:** A device for converting the direct current (DC) from the PV array into alternating current (AC), which is necessary for the connection of most devices and especially for the feed-in of solar energy into an existing transmission line. Inverters for PV systems usually include one or more MPP trackers, store operating data and monitor the grid connections of the PV system.

Master: The primary Inverter that is used and main interface for the unit; controls "slave" inverters.

Slave: One or more inverters that are linked to and controlled by a Master Inverter.

Operating States: [OFF], Standby, Run, Run/EmCharge, Error, Manual, Startup.

Menus: Meters, Settings, Diagnosis, Failure/Event, Operation, Direct Access.

SD Card: Maintains programmed parameters and archives crucial operational data.

**Maximum Power Point (MPP):** The operating point (on a current/voltage characteristic curve) of a PV array where the maximum power can be drawn. The actual MPP changes constantly depending e.g. on the level of solar irradiation (or shading) and the temperature.

**MPP Tracker:** Regulation of the power drawn so that a PV field remains as close as possible to the MPP. This operating point varies with the solar irradiation and the temperature conditions of the modules. MPP tracking optimizes the extraction of electrical power and is a feature of inverters and charge controllers.

**Photovoltaics (PV):** is the conversion of solar irradiation into electrical energy using special semiconductors called PV cells.

**Pintle/Ball Hitch:** Towing hitch; this is the primary connection between the trailer and the towing vehicle.

**PV Array:** Technical device for the conversion of solar energy into electrical energy. All electrically connected (in series and in parallel) PV modules of a PV system are referred to as the PV array.

**PV Cell:** An electronic component that generates electrical energy when irradiated with sunlight. Since the electrical voltage of a single PV cell is very low (approximately 0.5 V), multiple PV cells are combined as PV modules. The most common semiconductor material presently used for PV cells is silicon which is manufactured in different forms (monocrystalline, polycrystalline, amorphous). In addition to different mechanical variations, that are usually designed to increase the level of efficiency, completely new materials are currently being tested (cadmium telluride, cadmium indium sulfide, titanium dioxide and many others).

**PV Combiner Box:** Manages the circuits connecting the PV arrays, Charge Controller, and lights.

**PV Module:** Electrical connection of several PV cells encapsulated in an enclosure to protect the sensitive cells from mechanical stress and environmental influences.

**Safety Chains (Trailer):** Heavy-duty chains used to ensure the trailer and towing vehicle stay together even if the coupler (eg pintle/ball hitch) separate or fail. Make sure chains are attached to both units.

**SB Industrial Connector:** An industrial-grade electrical outlet; located on the exterior right of Enclosure. This is the most efficient connection point for charging the battery.

**Self Discharge:** Loss of battery charge while it is stored or not used. A higher ambient temperature has a strong influence on self discharge.

**Series Connection:** In this case the positive terminal of each battery is connected to the negative terminal of the next battery. There is only one circuit where current can flow. Series connection increases the voltage of the entire battery bank. If four 12 V batteries with a capacity of 100 Ah each are connected in series, the total voltage is  $4 \times 12 \text{ V} = 48 \text{ V}$ , while the total capacity remains at 100 Ah.

**Solar Energy:** Energy from sunlight or other solar irradiation (heat and/or UV radiation).

**Spider Box:** Connects to 50Amp Twist-lock outlet and has 6x 20A outlets (GFCI), 1x 30A outlet, and 1x 50A outlet. Provided only upon request.

**Split-Phase:** A split-phase system is a three-conductor single-phase distribution system, commonly used in North America, the UK, Australia and New Zealand for single-family residential and light commercial applications up to 100 kVA. Its primary advantage is that it saves conductor material since a single-phase system with one neutral conductor is used, while on the supply side of the grid configuration only one line conductor is necessary. Since there are two live conductors in the system, it is sometimes incorrectly referred to as "two-phase system". To avoid confusion with split-phase applications, it would be correct to call this power distribution system a three-conductor, single-phase, mid-point, neutral system.

**State of Charge (SOC):** the state of charge of the battery, see State of charge. If 25 Ah is taken from a 100-Ah battery, e.g. the state of charge (SOC) is 75%.

**State of Charge:** Describes the current amount of charge that can be drawn from the battery, in percent of the nominal capacity (100% = battery full, 0% = battery empty).

## 8.5 Inverter Events

Table 10 Event Codes

Display Number	Description
E101	Waiting mode
E102	Startup process
E103	Operation
E104	Operating on the generator (at external input)
E105	Operation on utility grid (at external input)
E106	Feeding-in grid operation (at external input)
E107	Sleep mode (slave in single-phase systems)
E108	Silent mode on utility grid
E110	Shutdown due to error
E115	Emergency charge
E118	Automatic start
E119	Manual start (transition from standby mode to operation)
E120	Manual stop (transition from operation to standby mode)
E122	End of energy saving mode
E129	External start (remote)
E130	External stop (remote)
E131	Start of automatic frequency synchronization
E132	End of automatic frequency synchronization
E202	(Partial) reset of BMS due to new battery
E203	State change, battery charging algorithm for float charge
E204	State change, battery charging algorithm for boost charge
E205	State change, battery charging algorithm for full charge
E206	State change into silent mode option
E207	State change, battery charging algorithm for equalization charge
E221	Status change battery-preservation mode level 1
E222	Status change battery-preservation mode level 2
E223	Status change battery-preservation mode level 3
E401	Automatic generator start due to set criteria (battery state of charge, power, time, etc.)
E402	Automatic generator stop due to set criteria (battery state of charge, power, time, etc.)
E403	Manual generator start
E404	Manual generator stop
E405	Manual error acknowledgment of generator error
E406	Source of generator request
E407	Current-regulated generator operation initiated
E408	Current-controlled generator operation stopped
E501	Grid request due to SOC (insufficient value)
E502	Release of grid due to SOC (exceeds)
E503	Grid request due to exceeding the power limit
E504	Release of grid due to falling below the power limit

Display Number	Description
E505	Manual grid request
E506	Manual grid release
E507	Feed-in started
E508	Feed-in stopped
E601	Relay 1 off
E602	Relay 1 on
E603	Relay 1 slave 1 off
E604	Relay 1 slave 1 on
E609	Transfer relay open
E610	Transfer relay closed
E611	Transfer relay on slave 1 open
E612	Transfer relay on slave 1 closed
E617	Relay 2 open
E618	Relay 2 closed
E619	Relay 2 slave 1 open
E620	Relay 2 slave 1 closed
E625	Digital input OFF (Low)
E626	Digital input ON (High)
E627	Digital input slave 1 to OFF (low)
E628	Digital input slave 1 to ON (high)
E705	Device start
E706	date, time changed
E707	New system configured in QCG
E708	Part 1 of firmware updated
E709	Part 2 of firmware updated
E710	Cluster firmware updated
E711	MMC/SD memory card inserted
E712	Parameters from MMC/SD memory card loaded
E851	Sunny Island Charger #1 detected
E852	Sunny Island Charger #2 detected
E853	Sunny Island Charger #3 detected
E854	Sunny Island Charger #4 detected
E901	SOC recalibration started
E902	SOC recalibration stopped
E903	Derating started
E904	Derating stopped
E905	Preventive self-disconnection to protect the battery from deep discharge

See Sunny Island Inverter User Manual for more information.

